

# interiors

RAILWAY INTERIORS INTERNATIONAL

SHOW ISSUE 2013

## Mixed fortunes

VIA Rail Canada's Maxime Thibault on the challenges of refurbishing such a diverse fleet

### Accessibility

The countries, operators and suppliers striving to make rolling stock more suitable for PRMs

### Refurbishment

Cost- and time-effective ways to innovate

SHOW ISSUE:  
FULL PREVIEW  
FROM PAGE 52

**Railway**  
& MASS TRANSIT  
**interiors**  
TECHNOLOGY + DESIGN  
**EXPO 2013**

12-14 November 2013  
Cologne, Germany

# RailPlan

CONSULTING

ENGINEERING

MANUFACTURING

INDUSTRIAL DESIGN

MECHANICAL SERVICES

## DEDICATION SINCE 1986

With expertise in consulting, engineering, manufacturing, industrial design, and mechanical services, RailPlan can take any project from concept, through production, to ensuring its entire lifespan. With a dedicated staff based out of its Baltimore Maryland headquarters, entire turn-key products to award winning interiors are developed to the highest standards. This coupled with the Mechanical Services Division's expert rolling stock maintenance for passenger rail service providers, creates the company's goal to ensure the full life cycle service of any passenger rail car.

**RailPlan International, Inc.**  
1200 Bernard Drive, Baltimore, MD 21223  
T: 410.947.5900 F: 410.947.0357  
[www.railplan.com](http://www.railplan.com)



## ENGINEERED PRODUCTS

RailPlan offers a wide range of innovative solutions for passenger rail that include:

- Gangway/Diaphragm
- Transfer Bridgeplate
- ADA Bathroom Module  
2011 Brunel Award  
Commendation





## COVER STORY

**6 VIA Rail Canada**  
 Maxime Thibault is tackling a dizzying variety of interior designs as part of VIA Rail Canada's quest to update the lion's share of its fleet - from intercity trains to sleeper services traversing the country



26



32

## FEATURES

**16 PRM**  
 Attempts to make rolling stock more accessible for all are gaining momentum

**26 Waratah**  
 The newest train to serve Sydney's suburbs gives passengers the benefits of smart air-conditioning, improved accessibility and flexible seating

**32 Refurbishment**  
 Beyond simple wear and tear replacements, refurbishment can offer operators a cost- and time-effective way to update their trains' configurations, equipment and branding in line with changed priorities

**43 Material innovations**  
 The inside story on the development of innovative materials for the rail industry - from composites to plywood to thermoplastic

**52 Show preview**  
 Make the most of your time at Railway and Mass-Transit Interiors Technology and Design Expo - to be held in Cologne, Germany, on 12-14 November 2013 - with our preview of some of the products and presentations set to make it an unmissable event

**104 Design in brief**  
 An Edwardian-inspired dining car refurbishment for the Royal Scotsman



16

# CONTENTS

## PRODUCTS AND SERVICES

<b>64 RailPlan</b> Lifecycle services	<b>80 Forbo</b> Flooring	<b>94 Julien Rail Solutions</b> Design and engineering
<b>66 Atlantic Design Projects</b> Design	<b>82 Franz Kiel</b> Seating	<b>96 Rogers Corporation</b> Materials
<b>68 Tiflex</b> Flooring	<b>84 Mtag Composites</b> Materials	<b>98 Rica Seats</b> Seating
<b>70 Hexis</b> Films	<b>86 Productive Plastics</b> Thermoforming	<b>100 Bakerbellfield</b> Components
<b>72 Gummiwerk Kraiburg</b> Materials	<b>88 Getzner Werkstoffe</b> Floating floors	<b>103 PCT</b> Composite components
<b>74 Transit Design Group</b> Lighting	<b>90 KorbaDesign</b> Component design	
<b>76 Boxmark</b> Leather	<b>92 Rail Interiors Solutions</b> Surfaces and soft furnishings	
<b>78 SBF</b> Lighting		



## WELCOME

The vision of luxury on the cover of this issue is what VIA Rail Canada passengers on the four-day Toronto-Vancouver 'Canadian' service can look forward to when the HEP1 cars are refurbished. It's just one project in a huge programme of updates for the carrier, encompassing multiple train models, routes and missions. In our feature on page 6, the man responsible for overseeing the projects, Maxime Thibault, explains how he is tackling this diversity – not only between the various trains, but in the case of the HEP1, even between cars. Complementing Thibault's insights, on page 94 Julien Rail Solutions details its input on components for the HEP1 cars.

One of the main targets for the HEP1 refurbishment is improving accessibility for PRMs. Indeed, Thibault believes the updated train will boast "the biggest universally accessible bedrooms ever seen in North America". And it seems he's not the only one working on this mission, as the theme of accessibility crops up frequently in this issue – from the extra-wide vestibules and hearing-loop augmentation on Sydney's newest commuter train (page 26) to the best practice detailed in our dedicated feature (page 16).

Doubtless there will also be a lot of PRM innovations on display at Railway and Mass-Transit Interiors Technology and Design Expo 2013 (which comes to Cologne, Germany on 12-14 November and is previewed from page 52), especially in light of the EC's push for better PRM facilities across Europe, and with countries such as the UK working towards a new legal standard. It appears the rail industry on both sides of the Atlantic is on track to a fairer system for all.

**Izzy Kington**, editor

## FREE ONLINE READER ENQUIRY SERVICE

REQUEST MORE DETAILS ABOUT THE ADVERTISERS IN THIS ISSUE ONLINE AT:  
[www.ukipme.com/railway](http://www.ukipme.com/railway)



RAILWAY INTERIORS INTERNATIONAL

Free  
subscription  
available



Email your comments: [railwayinteriors@ukipme.com](mailto:railwayinteriors@ukipme.com)

## interiors

RAILWAY INTERIORS INTERNATIONAL

**Editor** Izzy Kington  
**Editor-in-chief** Nick Bradley  
**Production editor** Alex Bradley  
**Chief sub editor** Andrew Pickering  
**Deputy chief sub editor** Nick Shepherd  
**Proofreaders** Frank Millard, Kari Wilkin

**Art director** James Sutcliffe  
**Art editor** Nicola Turner  
**Design** Louise Adams, Andy Bass, Anna Davie, Andrew Locke, Craig Marshall, Julie Welby, Ben White

**Head of production and logistics** Ian Donovan  
**Deputy production manager** Lewis Hopkins  
**Production team** Carole Doran, Cassie Inns, Robyn Skalsky

**Publication manager** Damien de Roche ([damien.deroche@ukipme.com](mailto:damien.deroche@ukipme.com))  
**International advertising sales** John Doherty ([john.doherty@ukipme.com](mailto:john.doherty@ukipme.com))

**CEO** Tony Robinson  
**Managing director** Graham Johnson  
**Editorial director** Anthony James

**Circulation and subscriptions manager** Suzie Matthews  
 Annual subscriptions: £60/US\$108

ISSN 1744-2281  
 Railway Interiors International.  
 This publication is protected  
 by copyright © 2013



Abinger House, Church Street,  
 Dorking, Surrey RH4 1DF, UK  
 Tel: +44 1306 743744  
 Fax: +44 1306 742525  
 Editorial fax: +44 1306 887546  
 Email: [railwayinteriors@ukipme.com](mailto:railwayinteriors@ukipme.com)

Printed by William Gibbons & Sons Ltd,  
 26 Planetary Road, Willenhall,  
 West Midlands, UK.

The views expressed in the articles and technical papers are those of the authors and are not necessarily endorsed by the publishers. While every care has been taken during production, the publisher does not accept any liability for errors that may have occurred.

Cover illustration: VIA Rail Canada's HEP1 train, courtesy of Julien Rail Solutions



# WORLD CLASS ENGINEERING SOLUTIONS



**TOUCHSCREEN**

**MEMBRANE**

**KEYPAD**

**LIGHTING**



Our seat controls and lighting systems have been in use on the world's leading airlines for many years, where they are selected for their high level of design, manufacture and reliability

They work just as well at ground level.

[www.waspswitches.co.uk](http://www.waspswitches.co.uk)







**Greater Sense of Space with lower Maintenance Costs** — thanks to completely homogenous, full-LED, carriage lighting, which makes travelling a pleasure. SBF luggage racks with an illuminated glass plate provide indirect ceiling lighting — for greater efficiency and comfort.



**Latest T5 Fluorescent and LED Technology**, which serves reliably even at 380 km/h: SBF supplies illuminated luggage rack flaps and the complete interior lighting system for high-speed trains all over the world.





**Brilliant Moments for Passengers:**  
SBF is a driver of innovation in the area of dynamic lighting, supplying complete ceiling structure lighting systems that do almost everything that is currently technically feasible, with options such as tunable white, RGB and colour temperature control according to biorhythm and season.

## ***Every Scenario deserves Passion for Light.***

Light in motion is our forte. SBF stands for bespoke ideas and complete solutions for rail vehicles. We develop and supply ceiling and lighting systems for direct or indirect lighting at the right light intensity and colour temperature – worldwide. As such, we ensure optimum lighting conditions and greater comfort for passengers. Moreover, the innovative range from SBF includes lighting with colour temperature control adapted to biorhythm or season.

# Continental shift

Maxime Thibault is tackling a dizzying variety of designs as part of VIA Rail Canada's quest to update the lion's share of its fleet - from intercity trains to sleeper services traversing the country

**C**anada's national rail passenger service, VIA Rail Canada, is in the middle of its biggest-ever capital investment scheme, which includes refurbishing a huge slice of its varied fleet. The plans include the overhaul of six 'RDC' diesel cars used between White River and Sudbury, Ontario, and Victoria and Courtenay, British Columbia; 98 'LRC' cars for the Windsor-Quebec City corridor; 59 'Renaissance' cars, mainly used in eastern Canada, between Montreal and Halifax; and 78 'HEP1' cars, which take passengers on a four-day journey between Toronto and Vancouver.

The task of overseeing these design projects was inherited by Maxime Thibault in 2008 when he became senior specialist for rolling stock and interior industrial design in the Technical Services department of VIA Rail's Operations branch.

Thibault says his role is more that of an integrator than a designer. "When you work for Bombardier or Alstom your mandate is to create a new interior - that's really different from what I'm doing," he explains. "Say you want to design a new vanity unit. When it's on the shop floor the



**MAIN:** Maxime Thibault  
**RIGHT:** The updated HEP1 Park Deluxe Bullet Lounge, with steps up to a panoramic viewing area



◊ MAXIME THIBAUT

Thibault has been in industrial design for 14 years. After completing a masters degree in environmental issues, he taught eco design at university. He then went on to own an industrial design company, designing everything from electronics to dentist cabinetry. He has been with VIA Rail for five years, based in Montreal.

At VIA Rail, Thibault is supported by a group of industrial designers, and also works with input from other departments. "Marketing, Customer Experience and On-board Personnel all have an impact on the design, because all these departments have a lot of experience, not of design, but of life on board," he comments. "To do a good design you have to understand these details."

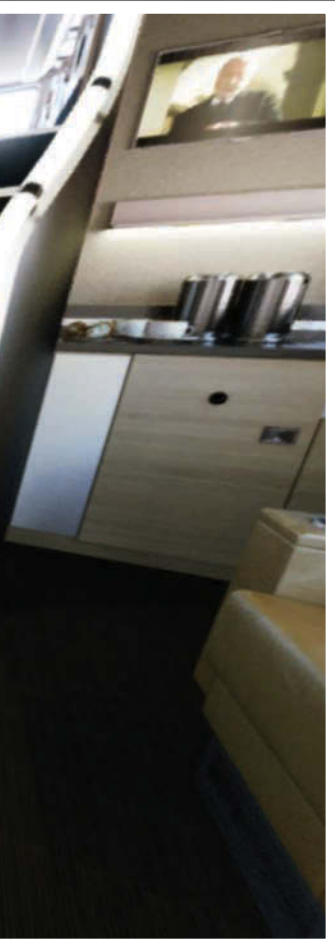



ABOVE: A wheelchair-accessible sleeper cabin on the Renaissance train  
LEFT: The HEP1 Park Deluxe Bullet Lounge during renovation



the major areas of improvement is accessibility. "The upgraded HEP1 Park and Chateau sleeper cars have the biggest universally accessible bedrooms ever seen in North America, and the biggest en-suite shower for a wheelchair user," says Thibault.

Each Park car features a sofa with a Murphy bed, and a portable table that can be attached under the sofa. "It was a big challenge to integrate all the requirements from the Canadian Transportation Agency, mostly the turning radius for wheelchair, which is really complex," says Thibault. "We created a mock-up to be sure we met all the requirements. I did so many tests to try to understand how a wheelchair user would get into the bed or access a closet; you can't do that with 3D modelling. With the table, I had to pay attention to such aspects as the pinch point, where the button for the rotating pivot could be accessed from, and where the table is stored."

The HEP1 Park Deluxe car also has hydraulic wheelchair lifts on each side, to facilitate access from the platform to the car. "The big challenge

design is fine, but when you want to put it in the car the interface might not work."

He cites the HEP1 car, where internal dimensions can vary by three-quarters of an inch between cars. "When you try to fit something into these 40 sleeper cars, and you have a gap difference of close to 1in, then your design cannot be done with pieces made on a production line all with the same dimensions," he says. "When you modify or add something to these cars, it has to be adjustable to fill the gap. When, for example, it's a counter surface and you have a gap at the end because it's not the same dimension, you don't want to fill it with silicon and stuff. We are trying to avoid that."

#### Access all areas

The refurbished HEP1 Park and Chateau Deluxe cars should be in service by June 2014. One of

**I did so many tests to try to understand how a wheelchair user would get into the bed or access a closet; you can't do that with 3D modelling**





THE ORIGINAL HIGH PERFORMANCE  
COMPOSITION LEATHER  
Anything else is a compromise

SAVE WEIGHT SAVE FUEL SAVE TIME SAVE MONEY

ULTRA HIGH PERFORMANCE  
COMPOSITION LEATHER MADE  
WITH REAL LEATHER FIBRE.

NATURALLY



Reduced weight and maintenance costs, improved appearance and branding from a sustainable technology.  
To discuss your upholstery and cladding programme requirements call **+44(0)1733 843 939** or email: [trains@eleathergroup.com](mailto:trains@eleathergroup.com)

**E-LEATHER<sup>®</sup>**

[www.eleathergroup.com](http://www.eleathergroup.com)

The latest and next-generation railcar and mass-transit design, materials and technology showcase!

image: © SCHOTT AG

**Railway**  
& MASS TRANSIT  
**interiors**  
TECHNOLOGY & DESIGN  
**EXPO 2013**

**FREE TO ATTEND!**

**100+**  
EXHIBITORS  
EXPECTED!

**THE MOST  
SIGNIFICANT  
DATES  
IN 2013?**

**12/13/14 NOVEMBER 2013**  
KÖLN MESSE, COLOGNE, GERMANY

**PLUS:** Featuring  
the largest  
free-to-attend  
railcar interiors  
conference ever  
to take place!

**Free to attend! Pre-register online now to receive your free entry pass!**

UKIP Media & Events Ltd, Abinger House, Church Street, Dorking, Surrey, RH4 1 DF. Tel: +44 1306 743 744 Email: damien.deroche@ukipme.com

**Register online: [www.railwayinteriors-expo.com](http://www.railwayinteriors-expo.com)**



## It's close to impossible to have a well-defined interior style at VIA Rail because each car has its own design

with that was to design for maintenance, because otherwise you can imagine the ice and snow getting stuck in it," says Thibault.

The car also features a new L-shaped bar with a quartz counter and stools. "Quartz is a de luxe material but you need it to be well attached to resist the G-force," says Thibault. "It's white, and with the wood contrasts, it looks incredible."

After the bar comes the Bullet Lounge (so named because of its shape). Tying in with the car's 1950s provenance, the team has gone for a retro look in this area. "We have an integrated sofa on both sides which provides 11 seating places, each with its own reading light, plus big armrests, all made of leather and fabric," adds Thibault.

From the Bullet Lounge, passengers can climb to a panoramic viewing area, included because the HEP1 passes through the Rockies. "We kept the same staircase design," says Thibault. "It's lit with two acrylic handrails, which have light passing through them, as per the original design."

### Spanish steps

Thibault has also been working on the overhaul of VIA Rail's LRC cars. "With the LRC, we completely revamped the economy-class section," he says. "The interior looks like a Spanish train because we have bright, contrasting colours – red, blue and yellow. You will rarely see such a colour combination in a Canadian train."



ABOVE: The HEP1's quartz-topped bar  
BELOW: The HEP1 Park cabin  
BOTTOM: Business class on the LRC

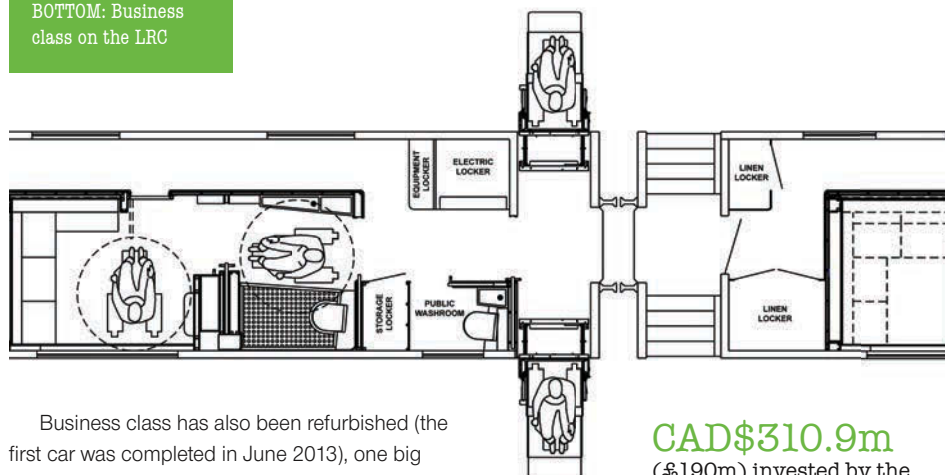

Business class has also been refurbished (the first car was completed in June 2013), one big difference being a change in seat configuration, from 2-2 to 2-1. Thin, leather-covered seats from Grammer have been used, with curved headrests for privacy. Their thinner profile means there is more room and easier access.

The LRC interiors display a notably different aesthetic to the HEP1 cars. This is because the carriages themselves are very different. VIA Rail's diverse fleet ranges from the stainless steel HEP1s built in the 1950s by Budd car, to the Bombardier LRCs dating from the late 1970s, to the Metro Cammell Renaissance cars made in the 1990s for the Channel Tunnel Nightstock project. "It's close to impossible to have a well-defined interior style at VIA Rail because each car has its own design," says Thibault. "For example, the Renaissance car is like an aircraft interior, while the HEP1 has flat surface panels with trims to fill the gaps. They each have their own style, so it's hard to have an influence on the design of the interior."

**CAD\$310.9m**

(£190m) invested by the Government of Canada since 2007 on upgrading VIA Rail's fleet

**4 million**

passengers carried in 2012

**12,500km**

passenger rail network

**450**

communities served

**396**

passenger cars in the fleet

**2,600**

employees



To read more on  
VIA Rail Canada  
see page 94

ABOVE: Economy class on the LRC  
BELOW: Business class on the LRC, during renovation

## You have to find a kind of universal design that will pass the test of time



It may be impossible to introduce a single aesthetic across VIA Rail's extremely varied fleet, but Thibault's designs are united by three key aims – maintainability, durability and environmental responsibility.

To optimise the first, he tries to use the same materials wherever possible. "We tried to use some of the same materials in the LRC and Renaissance cars, because different materials require different cleaning and maintenance procedures," says Thibault.

For durability, he has to think as much about fashion as the longevity of the materials. "You have to find a kind of universal design that will pass the test of time," says Thibault. "We try to stay stable but give some room for special designs and colours. I always have to keep that in mind when I have firms showing me concepts. They show me the latest fashion and I say 'It's nice today, but the project will be complete in four years!'"

So how does Thibault know when he has succeeded in creating a good design? "A good design sits well in the environment, taking into account the specific style of the car," he says. "Also, when the crew use it without any functional issues – this is another very important point, because the crews are the closest to the product. At the end of the day, I don't want the phone to ring in my office. There's always a period of testing in the car, and when I don't have any news, that's a good design." ❌

### ❖ COLD COMFORT

Railcars in Canada face obvious climatic challenges. "Components have to withstand temperatures from -40°C to 40°C," says Thibault. "Sometimes the supplier will just freak out and say they can't do it. But a car might be parked in the yard without electrical connection or heating for a few days, and if the material isn't resistant we could have cracking problems. With the plumbing, if it's not well drained, water will turn into ice and may burst the pipe." Thus VIA Rail uses heated cables around all its water pipes.

Another challenge is that snow often enters the vestibule between cars, particularly during the winter on the three-night Toronto-Vancouver route. "The vestibule is heated, but some snow always gets in," says Thibault. "This turns into ice, and when you arrive the door might be completely stuck, and you have passengers who have been on board for two days. The best solution is to provide new tools to remove the ice."



The latest and next-generation railcar and mass-transit design, materials and technology showcase!

image: © SCHOTT AG

# Railway & MASS TRANSIT interiors

TECHNOLOGY  DESIGN

**EXPO 2013**

**FREE TO ATTEND!**

**100+**  
EXHIBITORS  
EXPECTED!

# YOU NEED TO ATTEND THIS SHOW!

**12/13/14 NOVEMBER 2013**  
KÖLN MESSE, COLOGNE, GERMANY

**PLUS:** Featuring  
the largest  
free-to-attend  
railcar interiors  
conference ever  
to take place!

#### WHAT'S ON SHOW

Interior concepts / Composites / Interior refurbishment / Replacement parts / Seating / Fabrics / Floor coverings / Laminates / Safety equipment / Lighting / Galley equipment / Comfort products / Luggage racks / WiFi and communication systems / Refrigeration / Electronic displays / Food service equipment / Electrical and power management devices / Washrooms and restrooms **and much more...**

UKIP Media & Events Ltd, Abinger House, Church Street, Dorking, Surrey, RH4 1 DF. Tel: +44 1306 743 744 Email: damien.deroche@ukip.me.com

**Register online: [www.railwayinteriors-expo.com](http://www.railwayinteriors-expo.com)**



# Railway & MASS TRANSIT interiors

TECHNOLOGY  DESIGN

**EXPO 2013**

**100+**  
EXHIBITORS  
EXPECTED!

**12/13/14 NOVEMBER 2013**

**KÖLN MESSE, COLOGNE, GERMANY**

UKIP Media & Events Ltd, Abinger House, Church Street, Dorking, Surrey. RH4 1 DF. Tel: +44 1306 743 744 Email: [damien.deroche@ukipme.com](mailto:damien.deroche@ukipme.com)

**Register online: [www.railwayinteriors-expo.com](http://www.railwayinteriors-expo.com)**



**FREE TO ATTEND!**

**PLUS:** Featuring the largest free-to-attend railcar interiors conference ever to take place!

# REGISTER NOW FOR YOUR FREE ENTRY PASS!

[www.railwayinteriors-expo.com](http://www.railwayinteriors-expo.com)

UKIP Media & Events Ltd, Abinger House, Church Street, Dorking, Surrey. RH4 1 DF. Tel: +44 1306 743 744 Email: [damien.deroche@ukipme.com](mailto:damien.deroche@ukipme.com)

**Register online: [www.railwayinteriors-expo.com](http://www.railwayinteriors-expo.com)**



# All aboard





## Attempts to make rolling stock more accessible for all are gaining momentum

In 2008 the European Commission (EC) published a standard intended to improve the accessibility of all trains used on the interoperable system in Europe (i.e. 'heavy' rail vehicles, not 'light' vehicles such as metros and trams).

The technical specification for interoperability for persons of reduced mobility (PRM TSI) sets out comprehensive guidelines for new or refurbished carriages – for elements including seats, wheelchair spaces, doors, lighting, toilets, clearways, customer information systems, height changes, handrails, wheelchair-accessible sleeping accommodation and step positions for access and egress. The rules go into great detail, for example stipulating what fonts should be used for signage, the height of individual steps, the diameter of handrails and the maximum force needed to operate push buttons. The PRM TSI also extends to stations and other infrastructure, as well as telematic applications such as ticket booking systems.

By the EC's calculation around 80 million people in the EU – one in six – is classified as having a mild to severe disability, a ratio that increases to one in three for people more than 75 years old. In addition, the PRM category is not restricted to those with long-term disabilities, but includes those with temporary impairments (for example following an accident or operation), pregnant women, people travelling with children and various other groups.



Long Life Reliability  
does not cost the earth



# LumiMatrix

LED lighting solutions with high reliability.

[www.lpa-group.com](http://www.lpa-group.com)



CIRCULAR LED STRIP



LED STRIP



LED GEAR TRAY



FULL LED LUMINAIRE

#### LumiMatrix:

- Uses hundreds of lighting grade chip LEDs
- Wide variety of colour temperatures
- High level of uniformity
- High colour rendering index >80
- Flexible LED pitch and light output
- Total flexibility of shape and dimensions
- Built in or remote drive electronics
- Available as light engine (PCB), gear tray or full luminaire with diffuser
- Up to 17 years service life with up to 45% energy saving
- Analogue or PWM dimming
- Ambient light responsive control available

Visit us  
at Railway Mass  
Transit Interior Expo -  
Hall 9 / Stand 1080

**Railway  
& MASS TRANSIT  
interiors**  
TECHNOLOGY DESIGN  
EXPO





“Disability means just that – it does not just refer to those in wheelchairs,” says John Glover, a UK-based railway consultant. “Other relatively common forms of disability are blindness and deafness. There are no age limitations.”

### Legal impetus

In the UK, the EC’s PRM TSI replaced, for heavy rail, the very similar Rail Vehicle Accessibility Regulations (RVAR) that first came into force in 1998. RVAR itself was updated in 2010 to refocus on light rail, which is outside the scope of the PRM TSI and to apply lessons learned since it was introduced in 1998.

More than 7,600 rail vehicles in the country now meet either RVAR or the PRM TSI, including half of all trains. UK law requires all passenger rail vehicles to meet one of those two standards by 1 January 2020.

Meanwhile, the PRM TSI is currently being revised by the European Rail Agency. That revision includes a proposal that all European Union member states set their own deadlines for full or partial train accessibility.

In the USA, trains are subject to the Americans with Disabilities Act of 1990. The Architectural and Transportation Barriers Compliance Board (Access Board) provides the design criteria that forms the basis of legal standards issued by the US Department of Transportation. In February 2013 the Access Board announced plans to

ABOVE:  
Portable ramps  
on the UK’s  
Southeastern  
Rail are part  
of its Assisted  
Travel Service

### WHO IS CATEGORISED AS A PRM IN THE EC’S PRM TSI?

- Wheelchair users;
- People with limb impairment;
- People with ambulatory difficulties;
- Pregnant women;
- People with children;
- People with heavy or bulky luggage (but not oversized items);
- Elderly people;
- Visually impaired or blind people;
- Hearing impaired or deaf people;
- People who have difficulty in communicating or understanding the written or spoken language (including foreign people with lack of knowledge of the local language; people with communication difficulties; and people with sensory, psychological or intellectual impairments);
- People of small stature (including children).

## Disability means just that – it does not just refer to those in wheelchairs



LEFT: Colour-contrasting fittings on Southeastern’s Class 395

## ◀ MUNICH METRO

Munich's new metro, C2, is due to enter service by the end of 2013. N+P Industrial Design of Munich took care to integrate details that "are helpful for all users, but especially for PRM passengers", says Andreas Bergstraesser, partner at the company.

### HANDLES

The C2 has many easily accessible handles, some positioned near the ceiling, some at mid-height in the centre of the entrance area, and others near the seats. "People who are constrained in moving their arms will find suitable grabhandles of various kinds in several positions," says Bergstraesser.

### LIGHTING

Vertical LED tapes are fitted along the C2's door seals, and change colour when the doors open or shut. "This means a PRM is able to focus completely on walking safely," comments Bergstraesser. "The door status is perceived intuitively without causing a distraction."

### LEANING SUPPORTS

There are leaning supports next to the C2's entrance and near the bellows. "PRM passengers with walking aids do not need to find their way into the seating area, but are able to stay near the door using both the leaning support in front of the partition and the vertical handrail inside the door column," Bergstraesser explains.

update its current accessibility guidelines for rail vehicles that date from 1991. It has set up an advisory committee of 23 organisations to help with this task, including vehicle OEMs, operators, disability organisations and other stakeholders.

Paul Priestman, founding director of London-based design firm Priestmangoode and an advocate for inclusive design, believes that regulations such as these are just the starting point – rail companies should aim even higher. "They should be the bare minimum," he suggests. "Although rail has embraced PRM, the implementation of facilities can be quite clumsy."

### Implementation challenges

One of the biggest challenges for designers is fitting in certain PRM facilities (especially wheelchair spaces and universal toilets) without compromising the travel experience for others in what constitutes a limited space. "The more space taken up for specialist uses, the less there remains for the public in general," points out Glover. However, if designed intelligently, wheelchair spaces can also offer added benefits – when not occupied they can be used for prams, bicycles, drop-down seats or standing passengers.

The PRM TSI stipulates two wheelchair spaces in trains shorter than 205m, three for those between 205-300m and four for those longer than 300m. Trains that have standard toilets should also have a universal toilet; likewise, trains with

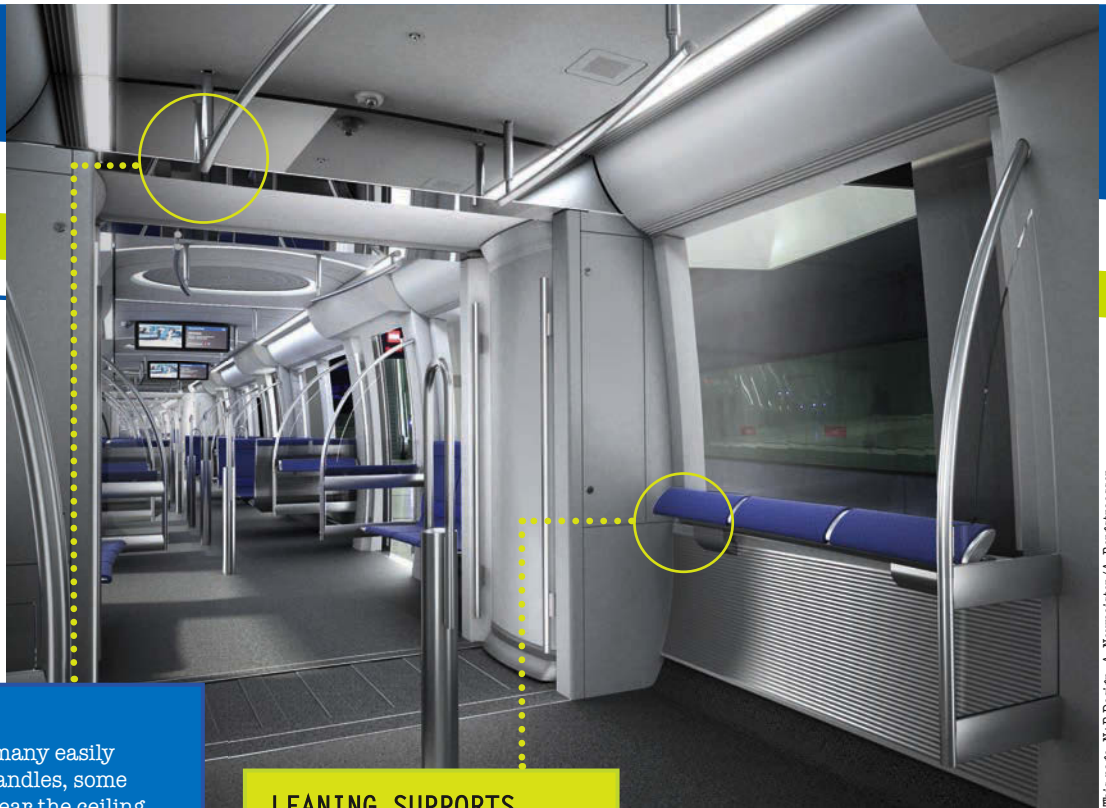

This page: N+P Design: A. Neumeister/A. Bergstraesser





# Did you know that Forbo Flooring Systems offers the widest flooring choice available for the rail market?

Forbo Flooring Systems is a global producer of flooring solutions, offering a truly comprehensive and compliant flooring product portfolio for rail applications including; vestibule, saloon, buffet car and toilets. Within the portfolio are entrance systems, vinyl, linoleum, flocked and carpet as well as adhesives and accessories.

We guarantee a combination of the best products in the market along with all the expert advice you may need, provided from one specialised supplier.

**marmoleum**<sup>®</sup><sub>FR</sub>

**tessera**<sup>®</sup><sub>FR</sub>

**flotex**<sup>®</sup><sub>FR</sub>

**coral**<sup>®</sup><sub>FR</sub>

**Visit us at;**

**Railway & Mass Transit  
Interiors Expo 2013**

Köln Messe – Hall 9

Cologne, Germany

12-14 November 2013

**For more information contact us;**

E-mail: [info@forbo-transportflooring.com](mailto:info@forbo-transportflooring.com)

Web: [www.forbo-flooring.com/transportation](http://www.forbo-flooring.com/transportation)

Telephone: +44 (0)1773 740629

AL-OU50-2000

galley solutions  
worldwide

## High Speed Convection Oven



Available in 3 variants: 32, 48 and 60 plus meals

**Aerolux - Reliability - Flexibility - Quality - Care**



**AEROLUX LTD** Chorley Road, Blackpool, Lancashire, FY3 7XQ, England  
Tel: +44 (0) 1253 396670 • Fax: +44 (0) 1253 300074 • Email: [sales@aerolux.co.uk](mailto:sales@aerolux.co.uk) • [www.aerolux.co.uk](http://www.aerolux.co.uk)





standard sleeping accommodation should include at least one wheelchair-accessible sleeping unit. At least 10% of seats should be designated as PRM priority seating. To promote interoperability, and avoid costly mistakes (after all, a carriage can have a life of 40 years), the PRM TSI lays down minimum dimensions for aspects such as wheelchair spaces, universal toilets and the width of doors.

Rail companies have learned a lot about the design of universal toilets in the past few years. There are many factors to consider beyond the obvious physical requirement of providing enough space for a person to manoeuvre their wheelchair and transfer between it and the toilet seat. To be truly universal, toilet floor and wall coverings should feature strongly contrasting tones to help people with sight impairments distinguish where the horizontal turns into the vertical. All amenities and controls must be at an accessible height. There should be a sufficient number of grab handles, which designers need to ensure are in contrasting colours and conveniently placed. Alarms (the PRM TSI stipulates at least two per cubicle) need to be on different surfaces, at different heights and distinct from other controls. All signs – as in the rest of the carriage – should



## Rail companies have learned a lot about the design of universal toilets in the past few years

contrast with their background and convey their message by pictorial and tactile means, rather than words. A visual or audible indication should be given on locking the door or operating the alarm. The PRM TSI also recommends that everything should be operable using a physical force of 20N or less, except for baby-changing facilities (25N), which should be included if separate facilities are not provided.

### The right response

In the past decade many rail companies have responded impressively to pressure from government and campaign groups, with a variety of solutions that take rail travel closer to the EC's goal of a barrier-free experience.

In France, SNCF is installing PRM features progressively on some of its Transilien trains, including a special seat for passengers who want to get out their wheelchair, with a vertically folding table alongside. SNCF is also working with various organisations on a harmonised system of signage and announcements to integrate what

### FLYING LESSONS

Rail may be able to learn from other branches of the transport industry. Last year, for instance, Priestmangoode unveiled a concept called Air Access, designed to improve the experience of air travel for PRM passengers. Based on an airline seat that is also a detachable wheelchair, the company believes it could also have an application for rail travel.

TOP: TRB Lightweight Structures' newly certified PRM toilet module, designed for new-build and refurbishment projects



visually impaired passengers experience on the platform with that on board the train. The state-owned rail group is testing its concepts at various demonstrator stations, and judging by the early reaction the 'seamless signage' will become part of its rail infrastructure.

In the UK, enhancing accessibility is a major part of First Capital Connect's refurbishment plans for its Class 365 fleet running between London King's Cross and Peterborough, Cambridge and King's Lynn, and will allow that fleet to operate past the country's 2020 legal deadline for all trains to be accessible. The trains will be fitted with a new wheelchair-accessible toilet in each four-carriage unit (to the latest specification and easier to use than that already in place), two wheelchair spaces instead of one, companion seating, and a new fully automated passenger information system with audio announcements as well as visual.

Many other European operators have some PRM facilities – but most recommend giving lots of notice before travel. One reason for this is that for the boarding process operators may need to deploy staff and ramps to help PRM passengers. And even if an operator does offer wheelchair accessibility, it may be for a different size of chair than in other places. It all adds up to a potentially stressful experience for people in the PRM category, for whom a spur-of-the-moment outing or change of plan can be off limits. Hopefully the EC's attempt to standardise what facilities are offered will mean a fairer system for all. ☒

**ABOVE:** Extra grab handles on the Class 395 – a train that set a new benchmark in accessibility standards  
**BELOW:** Southeastern's RVAR-compliant railcars provide information visually and aurally

## ☒ PRIDE OF BRITAIN

In the UK, Southeastern's Class 395 trains set a high standard for wheelchair accessibility in 2009. The carriages offer sufficient room for wheelchairs to manoeuvre into the space, easy access to the toilet, a bulwark of at least 800mm to support the back of the chair, and tip-up seats nearby for companions.

The trains formed part of London's successful bid for the 2012 Olympic and Paralympic Games, and during the events shuttled more than 2.4 million spectators to and from the Olympic Park. Most of the 29 'Javelin' trains are named after British Olympic and Paralympic medalists, chosen by Southeastern employees.

Also trying to build on the legacy of the Games, in December 2012 Transport for London announced plans including the expanded use of manual boarding ramps, which were used during the Games to bridge the gap between platform and train; an £18m commitment to make at least 95% of bus stops accessible by the end of 2016; more training for bus staff; and improvements to signage, its website and other services.

"Initiatives such as practical disability awareness training for staff, audio and visual announcements on buses, passenger assistance on the tube and travel mentoring, are a necessity for disabled people to travel independently," says Fazilet Hadi, group director, inclusive society, of the Royal National Institute of Blind People (RNIB). "These ideas should act as an example for other transport operators."





# IT'S BRIGHT



AND  
**SMART**



## 200,000 HOUR LED MAIN LIGHTING SYSTEMS FOR RAIL



MAIN LED LIGHTING - FRA/DOT LED HEADLIGHTS - LIGHTING CONTROL SYSTEMS  
FLORESCENT BALLASTS - CAPACITIVE STORAGE BASED EMERGENCY LED LIGHTING SYSTEMS.



[WWW.TDGDDESIGN.COM](http://WWW.TDGDDESIGN.COM)



# Cool operator



## ◀ WARATAH TIMELINE

<p>RailCorp (now Sydney Trains) calls for expressions of interest from potential suppliers for 29 single-deck eight-car trains and 36 double-deck eight-car trains</p>	<p>Initial tenders received from Downer, United Goninan, Bombardier and Siemens for the single-deck trains; and from Downer and United Goninan for the double-deck trains</p>	<p>Single-deck option abandoned on a value-for-money basis; RailCorp announces a re-tender for 72 double-deck eight-car sets, ultimately amended to 78 sets inclusive of six spare sets; Downer and United Goninan re-bid the project</p>	<p>Public-private-partnership project awarded to the Reliance Rail consortia, at that time consisting of Downer, AMP Capital, ABN Amro and Babcock &amp; Brown</p>	<p>Preliminary design submitted and approved</p>	<p>Revisions worked on; Downer, with joint venture partner Hitachi, commences design, procurement and manufacturing activities</p>	<p>Critical design review completed</p>
<p><b>2004</b></p>	<p><b>2005</b></p>	<p><b>2006</b></p>	<p><b>December 2006</b></p>	<p><b>January 2008</b></p>	<p><b>Mid 2008</b></p>	<p><b>June 2009</b></p>





The newest train to serve Sydney's suburbs gives passengers the benefits of smart air-conditioning, improved accessibility and flexible seating

**LEFT:** Extra-wide vestibules are just one of the features incorporated to optimise accessibility  
**BELOW:** Toilets and food cars don't feature on this commuter service – making room for more seats

**R**oss Spicer, now CEO of Downer Rail, was the project manager responsible for the next generation of trains to serve the suburban network of Sydney, Australia – a double-deck set named Waratah after the state flower of New South Wales.

"The New South Wales government realised the trains they had in service were ancient," Spicer says. "Half of them were more than 20 years old and a third of the fleet wasn't even air-conditioned. Following a massive growth in the use of commuter trains in Sydney in the early 2000s, it was decided that a significant investment for the future was needed."

**Vital statistics**

This investment involves a new fleet of 78 Waratah trains, replacing about half of Sydney's suburban stock, currently operated by Sydney Trains (formerly RailCorp). Each eight-car set has 894 seats, with standing room for another 604 passengers, meaning a total capacity of 1,412. There are no food cars or toilets – both were considered unnecessary as the longest route takes 45 minutes. The network does include a 15-minute route linking Sydney Airport and the city centre. To avoid blockages, luggage storage is restricted to the vestibule areas.

Testing and commissioning initiated on a four-car pre-production prototype	Dynamic type testing of the first eight-car set commences	Ross Spicer takes over as project director	First train delivered	First train enters passenger service	Ross Spicer appointed CEO of Downer Rail	Half the fleet in passenger service	Six trains delivered in one month (usual delivery rate is three per month)	Seventy-eighth train due to enter passenger service	Possible end of fleet maintenance contract – it may be extended for two additional periods, each of five years
<b>April 2010</b>	<b>August 2010</b>	<b>December 2010</b>	<b>April 2011</b>	<b>July 2011</b>	<b>April 2013</b>	<b>May 2013</b>	<b>June 2013</b>	<b>June 2014</b>	<b>2043</b>



## SPICER'S ROUTE

Hailing from Shropshire in the UK, Ross Spicer has worked in the railway industry for 25 years.

For the UK's rail network, he was involved in the development of British Rail/SNCF/SNCB Class 373 trains for Eurostar (1992-1996); and Class 220 Voyager (2000-2001), Class 221 Super Voyager (2000-2002) and Class 390 Pendolino (2001-2005) models for Virgin Trains, where he later became production director.

Spicer relocated to Sydney, Australia, to take over the Waratah project in December 2010 and became CEO of Downer Rail in April 2013.



The seat count of 894 also includes 16 dedicated wheelchair positions. Other features aimed at improving accessibility include extra-wide vestibules with redesigned grab rails, wide boarding and inter-car doors, and hearing loop augmentation for the public address system, all of which complies with Australia's Disability Standards for Accessible Public Transport regulation.

"During the initial design stages of the project, a full-scale half-car mock-up was produced to validate the interior design with passenger disability groups," Spicer recalls. "Many refinements were incorporated into the final interior design based on this feedback."

RailCorp's research also showed that the majority of commuters don't like sitting against the direction of travel. To address this, the saloons feature 'walkover' seats – a mechanism within each armrest

## The principle issue influencing the design of the interior was to provide robust vandalism and graffiti resistance

allows the passenger to switch the seat to face either direction. This action also operates a tilting mechanism in the seat base so that the angle between the seat base and backrest is maintained. "The walkover seat base cushion incorporates a deformable zone across the front edge, which collapses under impact during a collision," Spicer adds.

The seats are covered in a durable blue and yellow woollen moquette fabric. All the materials used in the train were selected for such characteristics as durability, crashworthiness, low maintenance and the ease with which graffiti can be removed.

"The principle issue influencing the design of the interior was to provide robust vandalism and graffiti resistance, while still providing a high-quality interior with aesthetic appeal," Spicer explains. "Graffiti and vandalism is a problem on the Australian train network." Thus, the interior window pans are made from punch-pressed aluminium, painted with a stippled anti-graffiti paint system. "This effect on the windows and walls makes them very easy to clean," he says.

Another key part of the design was the roof-mounted air-conditioning system, supplied by Sigma CoachAir Group of Australia. A comfortable temperature while travelling is important to Sydney's train passengers, many of whom consider 22°C as cold,

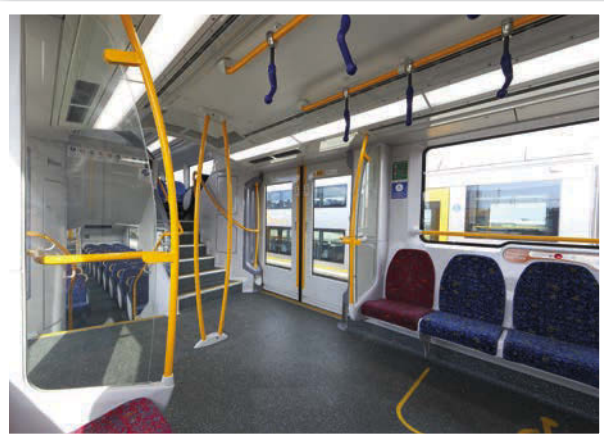

ABOVE: Seats can be switched by passengers to face the direction of their choice  
LEFT: Focus groups were consulted early on to ensure the trains would be accessible to all passengers



**RIGHT:** To facilitate evacuation, passengers can walk along the entire length of the train if necessary  
**BELOW:** Hearing aid loops are installed in the railcars to provide better coverage of announcements for passengers who are hard of hearing

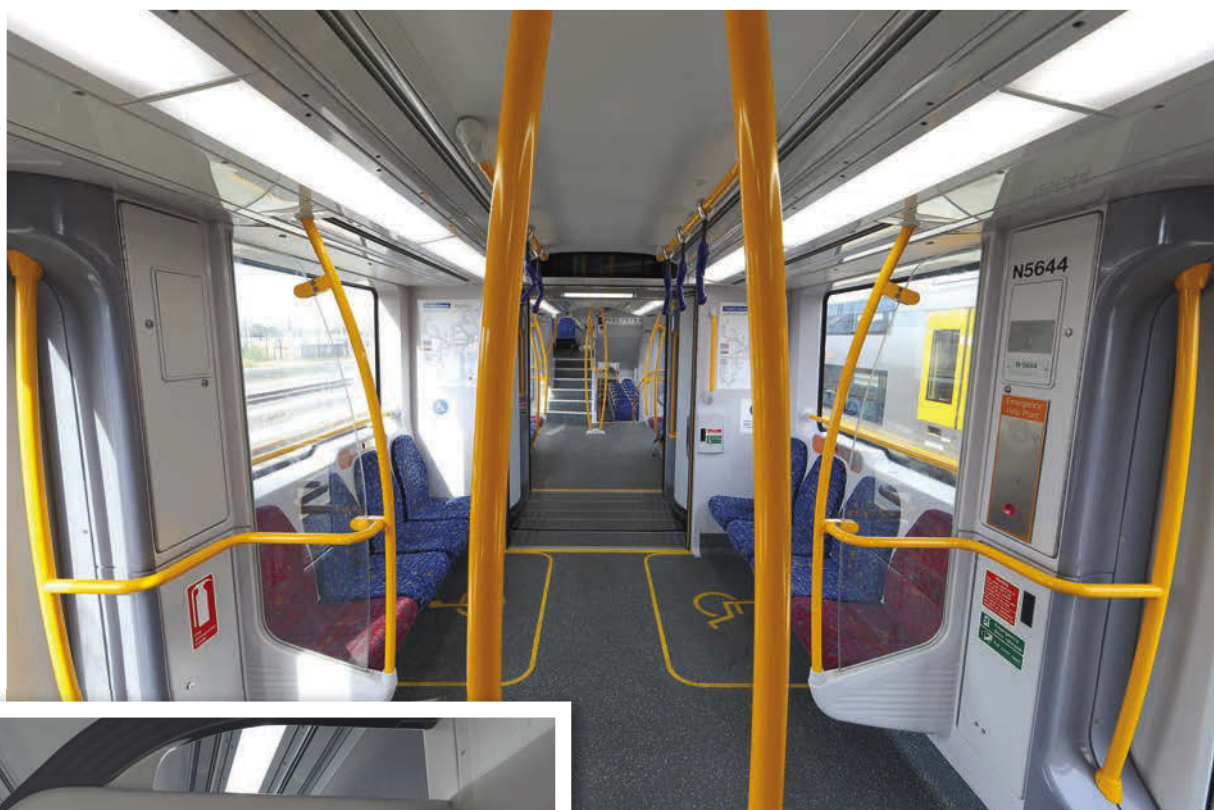

laughs Spicer. The three-stage climate control system adjusts in line with the number of passengers on board, using information from pressure-sensing air bags in the bogies' suspension (this information is also used by the braking system). Two independent cooling units in each car provide 38kW of cooling and 24kW of heat.

The air-conditioning system can be controlled in four independent zones – upper and lower decks and the vestibules, and also adjusts its fan speed based on whether doors are open or closed, to avoid wasting energy when passengers are boarding or alighting the train.

This is just the tip of the iceberg in terms of high-tech solutions on board. Downer developed a 'Smart Train' concept in-house, specifically for Waratah. One upshot of this is that the interiors utilise 100% LED lighting. Other Smart Train elements include the electronic train information system, which gives passengers information on stops; the train communications network, which features an Ethernet backbone with IP-addressable subsystem components; and the communications and surveillance system.

The Smart Train concept also extends to real-time monitoring of train subsystems, to assist crew with operational events and to help maintenance staff plan their activities.

On the other hand, wi-fi has been omitted. "There was little appetite from the New South Wales government to provide it, and it doesn't seem to bother many of the commuting passengers, who carry 3G or 4G phones anyway," says Spicer.

In terms of safety, the Downer Rail CEO believes Waratah has the highest crashworthiness performance of any train in Australia and any suburban train in the UK. The train was designed, manufactured and delivered within a safety assurance regime based on the Rail Safety and Standards Board UK guidelines. Highlights include a strengthened carriage and advanced fire-detection technology.

"It has also been configured so passengers can walk between carriages to get away from an incident, or walk through the entire

## ◀ SECURITY BLANKET

The communications and surveillance system incorporates 98 digital cameras throughout the eight-car set, including external cameras to enable the crew to monitor doors on curved platforms. More than 60TB of video – around two months of continuous footage – can be stored on board.

"There isn't a single position on the train where you can't be seen," says Ross Spicer. For extra security, there are emergency help points on the train, enabling direct communication with the guard.



LEFT: The driver's and guard's cabins were manufactured in Australia by Downer EDI and integrated with the railcar bodies that were produced in China

BELOW: With graffiti being a specific concern, the stippling effect on the interior walls allows for easier maintenance

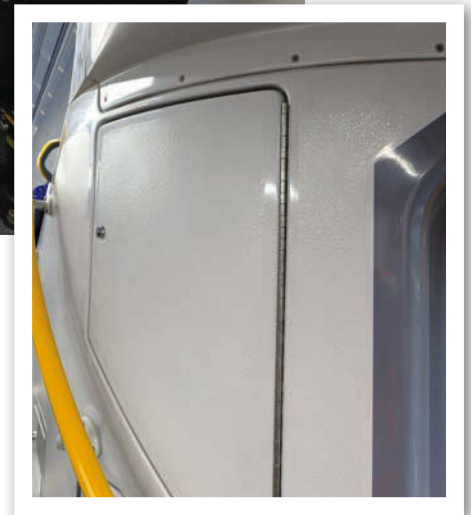

train if necessary for evacuation," says Spicer. "There is also an extra-wide stairwell manufactured from steel-reinforced GRP components that contains lockers for electrical equipment. The GRP system is a highly fire-retardant Modar resin."

### Global supply chain

Downer says that Australia did not have the capacity to manufacture the Waratah train alone. Thus the company entered into a manufacturing contract with Changchun Railway Vehicles (CRC) of China. A large amount of material procured directly by Downer – such as stainless steel, doors, brakes and windows – is "free-issued" to CRC (which also sources some of the materials in China) to incorporate into partially completed cars in Changchun, China. These are then sent (in shipments of two eight-car sets) from Dalian, China, to Downer's manufacturing facilities in Cardiff, approximately 170km north of Sydney.

Downer manufactures the modular crew cab in Cardiff before integration with the trailer driver cars delivered from CRC. The Cardiff facility is also responsible for the final fit-out and assembly of components, testing and commissioning. The set is then delivered to a purpose-built maintenance facility in Auburn, a Sydney suburb.

## Customer feedback has been amazing and the crews just love the new trains

"Logistics and shipping are coordinated by Downer from our Sydney office," says Spicer. "This includes managing all the in-bound freight from suppliers – on an ex-works basis so that we have precise information concerning shipping status."

As well as the previously mentioned Sigma Coachair Group, suppliers include Thales Australia (communications and surveillance), EKE Electronics (train information systems), Hitachi (traction), Knorr-Bremse (brakes and doors), Voith Turbo (couplers), Hübner (inter-car gangways), Miryung/BNG (stainless steel) and Sydac (simulators).

The Waratah train made its service debut in July 2011 and the last should be delivered by May 2014. As of September 2013, 52 trains are now in passenger service. According to Spicer, the new trains are "incredibly reliable and light years better" than the fleet they're replacing. "The service has gone from so bad to so good," he says. "Customer feedback has been amazing and the crews just love the new trains." ☺



# Protecting trains and riders for decades to come



**BISCO® Silicones**  
Performance in seating, sealing, and vibration management.

Visit us at Railway Interiors International - Cologne, Germany  
12 - 14 November, stand 4040 to learn more. [www.rogerscorp.com](http://www.rogerscorp.com)

# Second life





The first-class section of Eversholt Rail's Mark IV refurbishment concept

Refurbishment is not just about replacing tatty seat covers; it can be a cost- and time-effective way to update layouts and equipment in line with changed priorities

In April 2013, French operator SNCF launched a new brand; but it didn't need brand-new rolling stock to do so. Ouigo is a high-speed budget service modelled on low-cost airlines. To create it, SNCF refurbished stock coming up for half-life maintenance – four double-deck TGVs dating from the early 1990s.

Intended to complement SNCF's TGV service between the Paris area and the southeast of the country, the Ouigo trains have to stand up to intense use, running twice as frequently. They also have 20% more capacity – 1,268 seats compared with 1,018 on a classic TGV. SNCF has enabled

this by replacing the first-class carriage and bar car usually found on the TGV's lower level with more second-class seats. The result is a one-class train, with the same legroom and seat width as in the TGV's second-class cars. To avoid changing the mounting track, a 3-1 seat configuration is used in what was the first-class carriage, with a 2-2 layout elsewhere. Some first-class seats were refashioned as wheelchair-accessible seating, to meet the European Commission's upcoming Passengers of Reduced Mobility Technical Specification for Interoperability (PRM TSI) standard ahead of the 2020 deadline.

# ONLINE SUBSCRIPTION AND READER ENQUIRY SERVICE

**SUBSCRIBE  
NOW!**



Request more details about  
the advertisers in this issue  
of Railway Interiors  
International online at:

[www.ukipme.com/railway](http://www.ukipme.com/railway)



Also gone are some of the luggage racks – as with a low-cost airline, passengers pay extra if they want to take more than one piece of baggage and a handbag. SNCF also saved space by choosing a seat with a slimmer back, no reclining mechanisms and a simplified structure without footrests, enabling bags to be stowed underneath. Crucially, this seat (manufactured by Compin) is already in use on SNCF's TER regional trains. Likewise, SNCF specified upholstery fabrics already used on other services, to avoid having to go through fire safety tests again. With a tight budget and timetable, Ouigo is also deliberately low tech – SNCF did not change the lighting and has chosen to fit electric sockets in only three carriages – in which passengers can reserve a seat for an extra charge.

"The objective for Ouigo was to use colours that correspond to the brand, and materials already referenced by the suppliers; that's to say, a low-cost refit that could be done rapidly," explains Florence Rousseau, brand manager for the Ouigo project. "We didn't want to develop custom products especially for Ouigo. We had to use standard materials to arrive at something that is simple yet striking."

**RIGHT:** SNCF used standard materials to update existing equipment for its Ouigo trains  
**BELOW:** Inspired by low-cost airlines, SNCF removed first-class amenities and developed a fresh and simple brand for Ouigo



**We had to use standard materials to arrive at something simple yet striking**

#### ◀ CHEAP AND CHEERFUL

SNCF designed the Ouigo interior in-house, in line with a brand identity created by agency Carré Noir. Key to this brand is simplicity and a welcoming, young atmosphere – the service carries a high proportion of families, indeed 22% of ticket sales in the first few months were for children.

A colour scheme of cyan and fuchsia runs throughout the service, from livery (one of the few things developed especially for the train), through seat upholstery (turquoise with pink velour polka dots, and easy-to-clean pink texoid headrests) to tickets, uniforms, pictograms, website, app and even the partition-mounted posters requesting passengers to keep the noise down, put rubbish in the bin and not block the aisle.



This page: Arnaud Fevrier



LEFT: Beyond the makeover, Eversholt Rail and Atlantic Design see refurbishment as a way to reduce weight and costs  
BELOW: SNCF used refurbishment to create a simpler, one-class interior



S. Beaugues -Préparation Bischheim 3

From conception to delivery, the transformation took two years. “We dipped into all that we had in the SNCF toolbox to create this train, while giving it its own image,” says Rousseau. “It had to be inexpensive but not look cheap, and we had to show that we have used all SNCF’s savoir faire to create this train and guarantee the same level of safety, upkeep and cleanliness. The basics are the same standard as the TGV, it’s just not quite as comfortable, less expensive and the boarding system – away from town centre stations – is different.”

**Mixed message**

Eversholt Rail, which owns approximately one-third of the UK’s stock of passenger trains, also sees the value of refurbishment. Since late 2012 the company has unveiled two concepts utilising this approach. “In a growing rail market it’s a question of having a mix of new and refurbished trains; we can only fulfil the UK’s growing demand for trains by having both,” says Tim Burleigh, relationship development manager at Eversholt Rail. He argues that refurbishment can be a particularly economic way of modernising if timed to coincide with the periodic heavy maintenance that is scheduled in any case throughout the service life of rolling stock. “Even with a big fleet, if you stick to the heavy maintenance cycle it can typically be refurbished in two-and-a-half years, as opposed to waiting three plus years for a new train fleet,” he says.

Burleigh says luggage racks, side panels and window surrounds are typically preserved on these projects, Eversholt Rail’s approach being to focus investment on elements that are perhaps more noticeable to passengers (for example, seats, lighting, passenger information systems and air-conditioning) and add value for the operator (for example, CCTV).

This was the thinking behind Eversholt Rail’s four-class (standard, business, first and premium first) refurbishment concept

**The new seats alone save around half to three quarters of a tonne per standard-class coach**

for its Mark IV intercity carriages, a design created with Atlantic Design and realised into a mock-up by Solve 3D. “The whole philosophy was to put passengers first,” says Charles Greenway of Atlantic Design, who developed passenger information and seat reservation systems, along with a bench-style seat, for the project.

The latter is based on an aluminium structure designed to save weight. “With refurbishment we take a systems approach that considers operating and maintenance costs rather than just adding things to the existing train, which can have undesirable effects,” says Burleigh. “The new seats alone save around half to three quarters of a tonne per standard-class coach. That benefits the operator in terms of reduced track access charges and energy costs.” Compared with leasing new rolling stock, Eversholt Rail estimates the refurbished Mark IV fleet offers savings of around £1bn over the course of a typical franchise.

Another big upgrade is the lighting. “It’s very important in creating the right environment and making the train look modern,” says Burleigh. “It is also significant in terms of power



# Elastic Components for Your Ambition

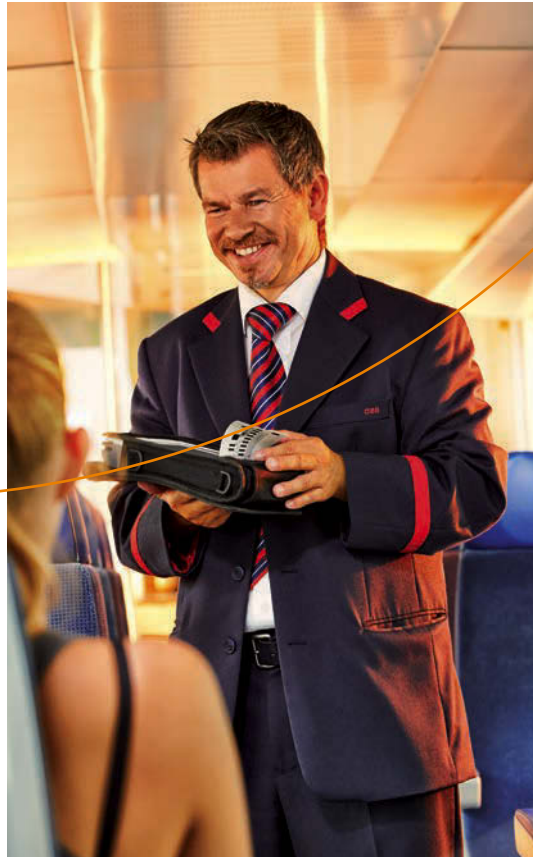
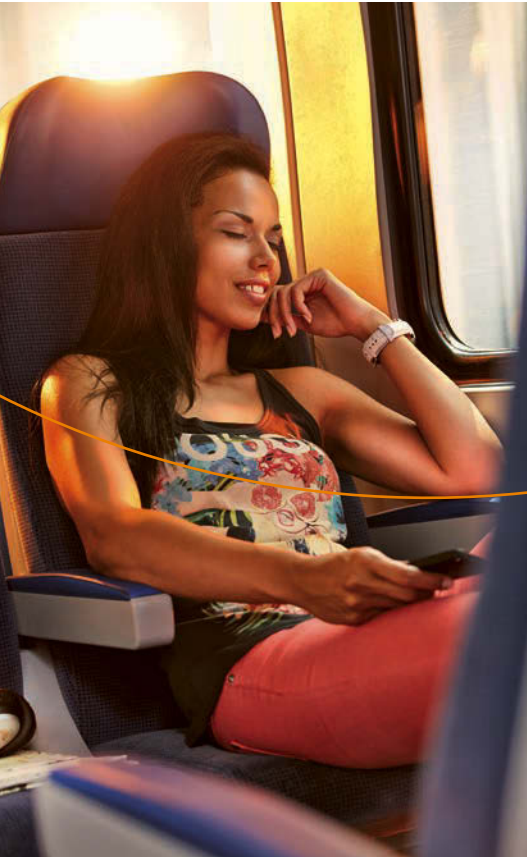

Floating floors for rolling stock from Getzner are adapted, manufactured and installed to your specific requirements. Our solutions improve passenger comfort, reduce the noise level in the carriage and lower life cycle costs.

**Materials key facts:**

- Excellent creep resistance
- Range of products for various loads
- Light weight
- Low construction height
- Flammability rating HL3 acc. CEN/TS 45545-2
- Resistant against water, chemicals and oils



**Getzner Werkstoffe GmbH**  
 Herrenau 5  
 6706 Bürs  
 Austria  
 T +43-5552-201-0  
 F +43-5552-201-1899  
 info.buers@getzner.com

[www.getzner.com](http://www.getzner.com)

Download  
 Brochure



**getzner**  
 the good vibrations company



**Productive Plastics, Inc.**  
Custom Plastic Thermoforming

## Lightweight Thermoformed Mass Transit Interior Components

At **Productive Plastics**, our commitment is to our customer. We bring to the table more than 55 years of experience and expertise in thermoforming, quality manufacturing, and cost effective solutions in the transportation industry. All focused to directly support and enable the success of your project.

### Productive Plastics Manufacturing:

55 Years of Thermoforming, Design, & Tooling Expertise  
ISO 9001:2008 Certified  
Lean Manufacturing Enterprise  
Value Added & Secondary Assembly Capabilities  
FRP/GRP and other material part conversion expertise  
Existing Tooling Available for Some Applications

### European and U.S. Compliant Parts:

EN-45545 (EU)  
NFPA 130 (USA)  
BS 6853 (UK)  
DIN 5510-2 (Germany)  
NF F 16101 (France)  
SMP 800C (Toxicity)  
BSS 7239 (Toxicity)

*Lightweight  
Durable  
Cost Effective  
Industry Compliant*

### Thermoformed Plastic Advantages

Lightweight  
Cost Effective  
U.S. and European  
Industry Compliant  
Graffiti, Chemical and  
Stain Resistant  
Recyclable Material

### Industry Applications

Seatbacks  
Armrests  
Window Shrouds  
Bulkhead Components  
Wall and Ceiling Panels

[www.productiveplastics.com](http://www.productiveplastics.com)

[respond@productiveplastics.com](mailto:respond@productiveplastics.com) • 1-856-778-4300



consumption and maintenance. With fluorescent tubes there are real obsolescence issues and they are difficult to keep clean. Smart LED lighting can be tuned to the characteristic of the particular vehicle and also be sensitive to levels of ambient light, thereby reducing your electricity consumption; we definitely see that as a key improvement.”

The Mark IV concept is also 4G enabled throughout, with a mix of three-pin and USB sockets and even inductive charging on tables in first class. “We are very keen to provide an architecture that is flexible and adaptable if things change, so our priority is to provide an Ethernet-style backbone that has the capacity to accommodate evolving information and data systems needs,” explains Burleigh.

While the Mark IV mock-up was showcased to the industry and passenger focus groups, Eversholt Rail is going further with its next proposal for the Class 321, by testing passengers’ reactions to a refurbished train in service. With Wabtec it has created a full-scale four-car demonstrator unit with two layouts. There is a metro configuration with fewer seats and enlarged vestibules designed to make access and egress quicker and easier, while the other layout retains the Class 321’s outer suburban arrangement, with the addition of new seats, including an enhanced first-class area. The demonstrator unit is due to enter passenger service with Greater Anglia in autumn 2013. Burleigh argues actual service is



ABOVE: Eversholt Rail is using a refurbished Class 321 to test layouts with the public

vital to test the merits of each layout, well ahead of franchising. “We’ve found that getting passenger and operator feedback at the right time is key to having well-developed enhancement options for refranchising,” he says. “The first step is to seek passenger feedback from existing users, but what we learn from this may be transferable to our other fleets and shape the enhancements that we offer for the rest of our assets. It can also shape our specifications for new-build trains.”

## FIVE HIGHLIGHTS OF THE MARK IV MOCK-UP

### 1. Connectivity

Standard and business class feature three-pin and USB power sockets. Looking to the future, in first class Eversholt Rail has included inductive phone charging points, compatible with the iPhone 5. The mock-up is 4G enabled.

### 2. Passenger information systems

Televic Rail supplied widescreen, full-colour TFT display systems that are fully compliant with PRM TSI. A seat reservation system – developed by Atlantic Design – displays a green light if the seat is unreserved, amber if reserved for another part of the route, and red if reserved for the current section.



### 3. Lighting

Both saloons and vestibules benefit from full LED lighting by McGeoch Technology, including dimmable white main lights and adjustable colour wash lighting in first and premium classes.



### 4. Soft furnishings

These include woven fabrics from Replin for curtains, blinds and the first-class bulkheads; Andrew Muirhead leather for seat upholstery; E-Leather for standard-class bulkheads and some seatbacks, dado panels and base cushions, as well as the premium-class backshells; and woven wool carpets from Axminster Carpets. Transcal retrimmed the business-class seats, and C D Curtain Contracts constructed curtains in first and premium class, and blinds in business class.

### 5. Seating

The configuration is 2+2 in standard (pictured below) and business class, 2+1 in first and 1+1 in premium first. Seats in the premium first, first and standard sections were provided by Rica Seating (which also supplied tables), with silicone foam from Rogers Corporation, while the business-class seats are by Grammer Seating. Highlights of the premium first seat include automatic recline, 360° swivel, a winged headrest and reclining lower leg support. The new double standard-class seat features a lightweight aluminium structure and black birch veneer. To prevent dirt accumulating in the join between the bottom and back pieces, this join has been positioned vertically further up than is traditional.



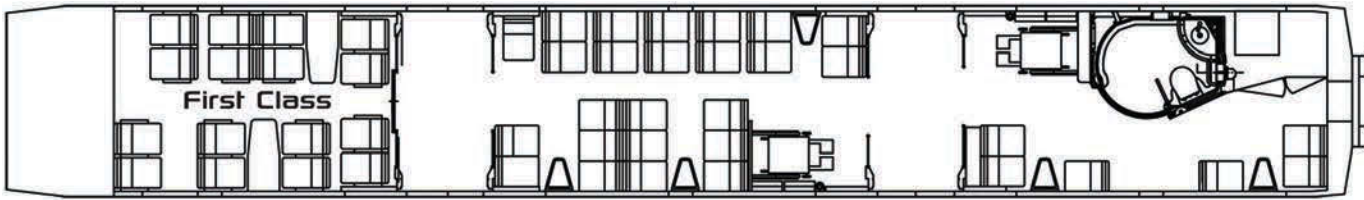

Passenger consultation also played an important role in SNCF's refurbishment of trains on its Paris-Clermont-Ferrand line, one of France's busiest regional routes. The project forms part of SNCF's policy of homogenising its diverse TéoZ, Lunéa, Corail and Intercités brands into simply Intercités. Passengers were consulted at Clermont-Ferrand and Limoges stations in 2009 and via a web forum – nearly 4,000 contributed their views to the design process. The first train was sent for refurbishment in April 2012 and delivered seven months later in November 2012.

The most common demands were for more space and greater cleanliness, stability and calm. Thus seats were reworked to provide greater comfort, plus integrated headrests that are easier to clean. In the face-to-face seat groups, 20cm of space was added, along with 'wallet' tables that fold completely upright to improve access for window seats. These tables were originally developed for the TGV by SNCF's Centre Ingénierie in collaboration with RCP Design.

### Power to the people

In response to another key demand, power sockets (which were previously reserved for first class) have been fitted throughout the train, along with LED reading lights. SNCF also improved the trains' suspension and made a lot of effort to reduce noise, choosing appropriate materials and fixation systems that would reduce the resonance and vibration of partitions and lighting columns. To meet PRM TSI regulations, the seating area for wheelchair users was enlarged, and wheelchair-accessible toilets were improved with new call buttons and safety rails. In standard toilets the water supply and hand dryers were improved.

SNCF also took the opportunity to try something different, creating completely new family spaces in the two service cars, incorporating child-size seats, adult seats that can fold up to create a play area on the floor, and a hygienic floor covering.

The later is a great example of the opportunity refurbishment offers, not just to save time and money, but perhaps even to innovate. Atlantic Design's Greenway reports a similar experience on the Eversholt Rail Mark IV project: "It's been fantastic to tackle refurbishment, because we've got so much scope to really change things." ☺

## It's been fantastic to tackle refurbishment, because we've got so much scope to change things

### ◀ LIVING HISTORY

While some refurbishments are carried out to bring an interior up to date, others aim to achieve the opposite. The Verde Canyon Railroad began carrying tourists in 1990, on a route dating from 1911 that takes in Arizona's "other grand canyon". Starting out with renovated cars that once ran along the USA's east coast, over the years more have been added and upgraded – including the 1936 Santa Fe Bell, which ran on the El Capitan line between Chicago and Los Angeles, and still wears original Hopi kachina motifs as well as its original leather-covered front and back bar.

The most luxurious carriage though is the caboose, which was built in 1929 for the Santa Fe line, and rescued from a Texas rail yard in 1987. Under the direction of general manager Robin Breaan, the renovation from industrial workhorse to luxurious parlour car for six people began early in 2004. The team remodelled, renovated or replaced every inch of the car, inside and out. "The biggest problem we had is that the car is constructed of steel," says Breaan. "We had to overcome problems with cutting, drilling and attaching the interior wood walls to the original steel structure."

The interior finish was completed by a team of specialists under the direction of Breaan, and including assistant general manager Roman Soqui. From the design stage to the implementation of a functional interior, complete with service galleys, bar and a comfortable restroom, Breaan meticulously oversaw detail.

Owner Dave Durbano wanted to make sure that as much as possible of the existing interior fixtures were saved and reused. "We used the original cupola seats, ladder rungs, hand rails, grips, even the old light fixtures," Soqui says. "I take great pride in knowing that I helped to restore the caboose and keep some of the history intact."



ABOVE: Eversholt Rail's Class 321 demonstrator features suburban (pictured) and metro configurations  
BELOW: Verde Canyon Railroad's caboose, before (left) and after (right) refurbishment





**DELUXE SERVICES, FROM COAST TO COAST.**

That's what Via Rail Canada wanted to provide to its passengers.  
And we made it happen.

**JULIEN**

Rail  
Solutions

Make your ideas real.

Design · Fabrication · Assembly · Installation

[julienrailsolutions.com](http://julienrailsolutions.com)  
[sales@julienrs.com](mailto:sales@julienrs.com)

# ONLINE SUBSCRIPTION AND READER ENQUIRY SERVICE

**SUBSCRIBE  
NOW!**



Request more details about  
the advertisers in this issue  
of Railway Interiors  
International online at:

[www.ukipme.com/railway](http://www.ukipme.com/railway)



# Material world

The inside story on the development of innovative materials for the rail industry - from composites to plywood to thermoplastic



**We've developed the resin to a price that is suited to rail interiors**

Dr Richard Horn, rail and industrial market sector manager at Cytec



**A key feature of the Inspiro project is that the entire floor is laid in one piece, reducing the assembly time dramatically**

Antonio Coelho, quality and product development director at Amorim Cork Composites



**Cross-bonded birch plywood is economical, with a more predictable and stable price than oil and aluminium**

Sakari Kainumaa, product manager for birch plywood at Metsä Wood



**We are bound to see pressure-forming gain more traction as designers and manufacturers discover what they can accomplish with it**

Rich Cort, sales and market development manager at Kydex

# Convinced that composites are not just for the auto and aircraft industries, Cytec has developed two new pre-pregs with rail's cost and fire safety requirements in mind



Over the past 25 years, Cytec has seen the popularity of technologies such as pre-pregs and sandwich panels soar in the aerospace, automotive and defence industries, due largely to their potential to offer big weight savings. Now the company wants to widen the use of these technologies in the rail industry.

At this year's Railway and Mass-Transit Interiors Technology and Design Expo (12-14 November) Cytec is set to unveil two new resin pre-preg systems developed specifically for rail in accordance with the EN45545-2:2013 fire requirements.

Developed to offer HL2 fire protection, MTM348FR is a curing epoxy resin pre-preg matrix that can be used for interior and exterior, structural and non-structural railcar components. Meanwhile Cytec is targeting the HL3 fire requirements with its in-development XMTM30 product, which is made from a natural bio-renewable resin for increased sustainability, and will be suitable for non-structural interior components.

Dr Richard Horn, rail and industrial market sector manager at Cytec, says the key advantage of the two new pre-pregs is that they enable the manufacture of thinner sections, taking weight out. "With SMC or wet lay-up, the product can end up around 4-6mm thick," he says. "The controlled structure of these pre-pregs – which typically consist of a glass fabric or carbon fibre with a controlled amount of resin – means you can get the panel thickness down to around 2-2.5mm."

Horn sees an appetite for further weight reductions in the rail industry. "This will reduce running costs," he says. "You use less energy and therefore fuel for accelerating and decelerating; you can reduce track access charges; and you can even run double-deck or longer trains within the same axle constraints, increasing capacity."



Cytec's new products are the result of more than two years of development, and it is now waiting for comments from a selection of its OEM and Tier 1 supplier customer base. "Our customers are making components with the materials and giving us feedback on how they perform, on handling, quality, processing, etc.," Horn says. "Initial feedback has been very positive and we are seeking other partners to push developments further." This feedback stage may last another 3-4 months.

### Is the price right?

So now that it has solved the technical challenges of fire requirements and mechanical performance, Cytec's next task is developing these products at a price acceptable for the rail industry – although Horn also points out that even a higher price is balanced out by reduced running costs. "We feel we've developed the resin to a price that is suited to rail interiors – you can put some very exotic things in to get the fire retardancy and there are some very expensive epoxy resins out there, but we've found other solutions. At the moment we are focusing on optimising the formatting."

Horn also points out that the way a material is made – the orientation of the fibres,

### PAST GLORIES

Cytec isn't a newcomer to the railway industry. Its MTM82S-C phenolic/glass pre-preg was used for the manufacture of standbacks for Bombardier's Electrostar Class 379 EMUs, running since March 2011 on the Stansted Express, and continues to be used on the Class 377/6 EMUs being manufactured for Southern Rail. Another success story is the use of its MTM29SFR epoxy/glass pre-preg with PET foam in the manufacture of nose cabs for a monorail in Kuala Lumpur.

the weight of the glass, where the resin is applied, etc – affects the process used to create the part, and therefore how much it costs to make. He hopes Cytec's experience in the auto world (which includes a strategic collaboration with Jaguar Land Rover) will pay dividends in this area. "We're doing a lot of work at the moment looking at high-value, high-volume, rapid manufacture for the automotive sector," Horn confirms. "Composites, particularly carbon fibre, have a history of being made by a cottage industry using hand lay-up, and expensive labour and tools. The automotive industry is looking to bring the cost down substantially and we certainly see some of that work spinning out into the rail market." ❌

### NATURAL SELECTION

Cytec's Dr Richard Horn sees bio resin systems as the future for sustainable composite materials and is already looking into how they might evolve. "We're very interested in developing it with natural fibres, so you have a 100%

bio-renewable material," he says. "It's early days and again it's a matter of achieving the right mechanical performance and formatting – trying to put the natural fibres down as quickly and economically as possible."

Cytec is additionally researching how materials can be recycled. "Going forward, I don't think it's acceptable to grind stuff up and use it as a filler in roads," Horn says. "You've got to get some value out of it at the end of its life."



# LIGHTWEIGHT INTERIORS?



Cytec understands the challenges facing the rail industry, and is adding two ground-breaking products to its rail portfolio that meet the fire requirements of EN45545:

- MTM<sup>®</sup>348FR epoxy prepregs for HL2
- XMTM30 prepregs for HL3, a development product that uses a resin derived from a bio-renewable sustainable resource

**Choose Cytec's prepreg technology**

To find out more, visit stand 8060 at Railway Interiors, 19-21 November, Cologne, or visit [Cytec.com](http://Cytec.com)

**CYTEC** | DELIVERING TECHNOLOGY BEYOND  
OUR CUSTOMERS' IMAGINATION™

[CYTEC.COM](http://CYTEC.COM)



www.amorimcorkcomposites.com  
Ecotrain is a R&D project that use cork as a core material for railway interior components floor and sidewall panels. Ecotrain solutions takes the advantage of cork lightness and both acoustical and thermal insulation.

### The Main Advantages:

- Weight reduction
- Increased thermal and acoustical insulation
- Reduction of CO<sub>2</sub> emissions
- Cost reduction

### EcoTrain sidewall panels:

Fibre glass/Resin system

CORECORK®

Fibre glass/Resin system

### EcoTrain floor panels:

Floor covering

Aluminium

CORECORK®

Aluminium

[www.amorimcorkcomposites.com](http://www.amorimcorkcomposites.com)

#### PARTNERS



#### CONTACTS

Project Leader - Amorim Cork Composites  
Rua de Meladas, 260 P.O. Box 1  
4536-902 Mozelos VFR · Portugal

Phone: +351 227 475 300  
Fax: +351 227 475 301  
Email: [acoelho.acc@amorim.com](mailto:acoelho.acc@amorim.com)



## A bio-composite replacement for plywood flooring developed by Amorim Cork Composites is now being implemented on Siemens' Inspiro platform



One of the most recent developments by Amorim Cork Composites (ACC) for the rail interior market has been the Alucork floor system. Designed around a new composite panel made with aluminium skins and a cork core, the floor is then customised to meet each platform's requirements, such as the substructure layout, dimensions and positioning of hand rails.

Alucork is a clean-sheet design that took around five years to develop, an idea that came from discussions ACC had with OEMs as well as purchasing and engineering teams. "They wanted a cost-competitive and



reliable solution to replace plywood for flooring due to the weight, durability issues and lifecycle cost," reveals Antonio Coelho, quality and product development director at ACC. "The most challenging aspect of the development was to open people's minds to something different, but once the first test results came back, we gained momentum."

Coelho says that compared with the traditional plywood rail floors it is intended to replace, Alucork is at least 30% lighter, with better acoustic and thermal insulation properties at the same thickness. "Alucork flooring is typically 8.9kg/m<sup>2</sup> compared with 12-14kg/m<sup>2</sup> in current plywood rail products," he states. "A further advantage is durability – Alucork is much less

### GO GREEN

ACC's Antonio Coelho thinks success in the composites sector is down to ability to upgrade products swiftly, and he points to sustainability as a key future battleground. "Natural raw materials and improved EOL

recycling strategies are being considered more and more," he notes.

Alucork addresses this with a natural, recyclable material (cork) at its core, making it a bio-composite. AAC is careful how it sources raw

materials and is mindful of the adaptability of its manufacturing process to facilities worldwide, to minimise carbon footprint (and lead time). Coelho says Alucork's footprint is at least 50% lower than current plywood products.

sensitive to water absorption than plywood, so it stands up better to washing and humidity. In terms of safety, the product was developed to meet the most demanding class (HL3) in the new CEN/TS 45545-2 fire standard and is also compliant with NF F16-101 (M1 F1) and ASTM E-162/ASTM E-662/ASTM E-648."

### Perfect timing

A big boost came when Alucork was chosen for the flooring on Siemens' Inspiro platform – the start of a three-year joint development between the companies. Siemens Vienna began production of the first Inspiro metros at the end of 2012, for Warsaw, Poland. "A key feature of the Inspiro project is that the entire floor is laid in one piece, reducing the assembly time dramatically," Coelho explains. "Another benefit is that as a result of Alucork's acoustic and thermal insulation characteristics, no additional insulation was required in the railcar."

AAC has since developed other designs – with further panels – to fit more traditional assembly procedures. However, it has also developed a system whereby pieces click together, so the product still enables faster assembly.

Alucork is made in two thicknesses – 20mm and 30mm – but is fully customisable to meet the acoustic and thermal requirements of each train. The new composite panel can also be used for other rail applications, including wall partitions and ceiling components. Coelho says Alucork

is a particularly good solution for trains with low floors – metros, light rail and people-movers, etc – and for any passenger decks where improved thermal and acoustic comfort is necessary.

The floor system is currently being considered for projects in various countries. AAC is also in the final stages of testing to launch onto the US market and introduce Alucork as an alternative to plymetal and phenolic panels. ✕



## Sustainable birch from a reliable supply provides a solid basis for continuous innovation at Metsä Wood



**F**or Metsä Wood, there is no end to its R&D work – it is continuously developing new products in-house at its facilities in Finland. “We possess a unique flexibility when it comes to serving our customers’ needs – we can engineer a wood to most requirements in terms of size, strength and overlays,” promises Sakari Kainumaa, product manager for birch plywood.

The company’s focus is on the possibilities offered by cross-bonded birch plywood. “It’s economical, with a more predictable and stable price than oil and aluminium,” Kainumaa says. Sourced from fully renewable forests, mainly in Finland, the birch is also certified to PEFC. “This ensures the sustainability of the supply chain as well as the forestry operations.”

### Nature’s finest

Metsä Wood products made with this natural raw material include Phoenix and Sonex plywood panels, which can be used for train floors, sub-floors and walls. Phoenix features a flameproof aluminium surface and has been tailored to meet prEN 45545-2:2012 requirements set to R10 for the Hazard Levels HL1, HL2 and HL3. “For floor composites, the requirements laid out in prEN 45545-2:2012 are the same as in the just-published EN 45545-2:2013,” Kainumaa states. “The Phoenix family also meets the stringent

British BS 6853 standard, as well as German, French, Italian and Spanish standards. This was a big challenge in development – each country has its own standards and old rules, so it was quite difficult to meet everyone’s requirements.”

Sonex Light, meanwhile, is designed to reduce the propagation of noise between exterior and passenger spaces. It features a cork rubber product from Amorim, which Kainumaa says is ideal for railcars where a lighter weight is needed.

“Sonex Light and Phoenix can be used together to create a product that ticks fire and sound insulation requirements,” Kainumaa adds.

Both Phoenix and Sonex Light products are now in use, and Kainumaa reports the company has received “plenty of enquiries”. ☒

### WEIGHTY ISSUE

Much is often made of a product’s weight per square metre, but for Sakari Kainumaa, these discussions miss the point. “There’s not enough emphasis on total construction weight,” he says. “By increasing the thickness of the plywood you could create a much stronger floor, requiring fewer metal supports, making your total construction lighter. At 700kg/m<sup>2</sup>, birch plywood is very strong and lightweight compared with aluminium (2,700kg/m<sup>3</sup>) and steel (7,800kg/m<sup>3</sup>), so that’s why we advise construction designers to look at the bigger picture and not just focus on one element in isolation.”



### SEALS OF APPROVAL FOR PHOENIX AND SONEX LIGHT

Plywoods from Metsä have been through some of most stringent approvals processes. These include:

- European Norm prEN 45545-2:2012: R10 for Hazard Levels HL1, HL2 and HL3 (equal to EN 45545-2:2013);
- DIN 5510-2 2009: SF1 to SF3;
- NFX 10702/NFX 70100, NF F 16101:1988, NF P92-501:1995, NF P 92-507:2004: M1 and F0 (Sonex Light M1 and F1);
- UNE 23721:1990, UNE 23727:1990: M1 and F0 (Sonex Light M1 and F1);
- BS 6853:1999: category 1A (Sonex Light 1B);
- ASTM E162, ASTM E662, Bombardier SMP 800C, Boeing BSS 7239 (Sonex Light);
- EN 13501-1:2007 B-s1,d0 (Phoenix);
- CEI UNI 11170:2010: limits LR1, LR2, LR3 and LR4.





# NEW METSÄ WOOD PLYWOOD WITH ADDED PROTECTION AGAINST FIRE AND NOISE

## METSÄ WOOD PHOENIX

Vehicle floors must withstand fire according to various standards and requirements. Metsä Wood Phoenix plywood panels are composite structure panels made of birch plywood, sound reduction material and an aluminum combination coating. As a new feature, the Phoenix fire protection panel is now also sound-insulating.

## METSÄ WOOD SONEX

Noise can be controlled by choosing the right vehicle materials. Metsä Wood Sonex sound insulating plywood is used to reduce the propagation of sound between exterior and interior spaces such as the motor and passenger area.

READ MORE ABOUT METSÄ WOOD PHOENIX AND SONEX AT

[WWW.METSAWOOD.COM](http://WWW.METSAWOOD.COM) →



METSÄ WOOD PLYWOOD  
RENEWABLE AND SUSTAINABLE MATERIAL



PEFC™  
PEFC/02-31-03



**MetsäWood**

## Ensuring a huge palette of colours and finishes was one of the key targets during the development of Kydex's latest thermoplastic



**K**ydex 2200LT is a thermoplastic material designed for rail interior applications such as armrests, seatbacks, seat side panels and trays, window shrouds, wainscoting, and bulkhead and ceiling components. "Its development was prompted by the rail market's need for a lightweight product that met the flame, smoke and toxicity (FST) requirements, while retaining excellent mechanical characteristics and aesthetics," says Rich Cort, Kydex's sales and market development manager for the northeast USA. In fact the final product meets 49 CFR 238 flame spread and smoke development requirements as well as being compliant to SMP800C and BSS7239 toxicity specifications.

### Designer touches

Another crucial part in the development was to ensure designers had a huge range of aesthetic possibilities. "Colour is always central to design, influencing space perception and mood," Cort adds. Thus Kydex 2200LT is available in a "practically limitless" colour palette. A selection of textures can also be tailored. "They can feature elegant branding in fine detail, with logos, angles and undercuts and virtually seamless fitting," Cort goes on to explain. "Speciality films such as PVF are available in custom decorative prints and can be laminated and embossed onto the sheet."

Cort contends that because colours and textures are moulded into the thermoplastic parts, secondary finishing operations – such as painting or refinishing to maintain texture consistencies – are eliminated, in doing so reducing manufacturing costs. "And as the colour is integral through the material and not applied as a coat, parts require little cosmetic maintenance – they are resistant to chipping, cracking and discolouration. Such durability is one of the reasons our thermoplastic is often selected as a material when worn-out components are replaced in refurb projects. And when they do eventually come to the end of their life, they can be recycled."

Kydex says further savings are made thanks to the production efficiency of the thermoforming

process. "It typically generates more parts per hour per mould than more traditional materials, often in a ratio of 8:1," Cort reveals. "Initial moulds for part prototyping are also low in cost, giving greater scope for pre-production design changes, so designers can experiment with their designs. The production moulds, usually temperature controlled and made from aluminium, are low cost considering that the mould lifecycle often exceeds 20,000 parts before replacement."

Depending on the thickness of the sheet, Kydex 2200LT weighs in at 2-6kg/m<sup>2</sup>. Cort says it also has a very low specific gravity, especially compared with fibreglass, while its formability at low temperatures (182-196°C) enables designers to specify complex geometries and shapes.

"We are bound to see pressure-forming gain more traction as designers and manufacturers discover what they can accomplish with it," he says. "The combination of air pressure and vacuum with more sophisticated processing controls for tool and heat temperatures opens up a universe of design possibilities, at thinner gauges, resulting in lighter parts and more refined designs – all without wall thinning and additional processes common in other types of forming." ❌

### ▶ PACE OF CHANGE

Kydex's Rich Cort believes the lightweight materials evolution is happening quickly. "Design is becoming a stronger focus and demand for lightness is becoming more common and rigorous, some even imposing fines per railcar if weight limits are exceeded," he says. "The technologies are rapidly adapting to meet this demand."

Cort also believes the regulatory landscape is a strong driver for progress. "If materials can't meet or exceed the regulations, they simply cannot participate in the programmes," he insists. "We will continue to develop rail products that meet and anticipate the increasingly stringent specifications, including stricter heat release and lightweight requirements. You will also see us continuing to focus on design, with expanded colour and texture possibilities."





**NEW TRACKS  
OF THOUGHT  
TO TRANSPORT YOUR  
IDEAS INTO  
REALITY**

Compliance and fresh  
design seamlessly converge  
with KYDEX® thermoplastics.

**Start your journey today**  
at [www.KYDEX.com/transit](http://www.KYDEX.com/transit)

© 2013 KYDEX, LLC. All rights reserved. KYDEX is a registered trademark of KYDEX, LLC.

**KYDEX**  
THERMOPLASTIC SHEET

ISO 9001 and 14001 Certified | [KYDEX.com](http://KYDEX.com)

KYDEX® sheet for rail interior components meets:  
Docket 90A, ASTM E-162 & 662, SMP 800C

# Do not miss this show!

**Railway**  
& MASS TRANSIT  
**interiors**  
TECHNOLOGY + DESIGN  
**EXPO 2013**

Anyone involved in the purchase, design, outfitting or management of railcar and mass-transit interiors will find **Railway and Mass-Transit Interiors Technology and Design Expo 2013** an absolutely unmissable show. Held in Cologne, Germany, on 12-14 November, the event is expected to feature more than 100 exhibitors and one of the strongest conference line-ups of the year

## 3 REASONS WHY YOU MUST ATTEND

### 1 To experience the latest and greatest product innovations

The Expo is the international showcase of everything within a railcar: the latest seats, washroom facilities, composites and other materials, soft furnishings, lighting, flooring, infotainment, catering solutions, HVAC, anti-vandalism technologies, safety equipment, cleaning products and security solutions. It is also the perfect place to meet designers, system integrators, maintenance companies and other service providers.

### 2 To engage with the industry's leading experts

A free-to-attend Open Technology and Design Forum will run on all three days of the event, featuring 60+ of the best speakers in the industry. Topics will include train interior concepts, the latest advances in composites and other materials, infotainment and strategies for ancillary revenue generation, flooring, improving the passenger experience, security and safety issues, accessibility, seating, lighting, textiles and connectivity.

### 3 To network with contemporaries from all over the world

Railway and Mass-Transit Interiors Technology and Design Expo regularly attracts in excess of 2,000 attendees from around the world – it really is a truly global networking opportunity. Over the past 10 years, the show has proved to be of major benefit for visiting key decision-makers from almost every major railcar manufacturer in the world, as well as numerous national rail and mass-transit operating companies.





## MEDIA SYSTEM

In its role as a European representative for Funtoro, **Molpir** will demonstrate the media-on-demand system, a solution that can be integrated into trains, coaches and buses. Funtoro offers an independent choice of movies, music, pictures, audio books, DVB-T or satellite TV programmes, internet browsing, games and other options – for more than 72 passengers. Each passenger accesses content individually, through their own touchscreen monitor and headphones.

Molpir offers the complete solution, tailor-made to customers' needs – from the initial idea, through the design and development of the installation kit, to the installation itself, system launch and maintenance support.

**Stand 3160**

## REFURB PARTNER

Leather and textile refurbishment services will be promoted on **Artex's** stand. The company has been refurbishing trains since 1928. Its approach is to take overall responsibility for the project, also refurbishing colour, foam, wood and metal.

Artex takes on projects from 50-50,000 carriages, and has customers both large and small, from all over Europe. These customers include Bombardier and EuroMaint. The company has production facilities in Sweden, Estonia and Latvia. **Stand 2040**



**KEYNOTE  
SPEECH**

## DESIGN EXPERT

At the Expo, **Tangerine** will highlight more than 20 years of experience in transport interior and seating design projects, an approach that entails the creation of tailored passenger experiences drawn from research and insights. The company has delivered transport interior and seating projects for clients including Heathrow Express, British Airways, Iberia, Asiana, Korean Aerospace Industries and Toyota. Current projects include working with B/E Aerospace in Europe and the USA on cabin interiors.

For the Heathrow Express refurbishment project, Tangerine was invited to work on first-class concepts along with other agencies. "Having design expertise and experience in different sectors of industry, particularly transport, means we can bring creative, innovative solutions and strategic business thinking to railway interior projects," explains Martin Darbyshire, managing director of Tangerine, who will deliver a keynote speech on the design-led transformation of passenger experiences at the Open Technology and Design Forum.



## CATERING FOR ALL TASTES

**Aerolux** will showcase its range of onboard catering equipment for the rail industry, which includes: AL-CPF24-1000, a compact and self-contained refrigeration unit designed to keep pre-chilled food cool; AL-OU50-2000-032/048ER, a high-speed convection oven for heating pre-cooked and chilled meals; and beverage-making units. Aerolux can also design and manufacture catering display and serving trolleys customised to operators' needs.

Aerolux's rail clients – which have included Virgin Trains, Kelox, Alstom and Multirail – can also benefit from the company's considerable experience in the aviation sector.

**Stand 1025**



## EXHIBITOR IN FOCUS

**Rolf Schollmeyer**, composite applications, **Gummiwerk Kraiburg**



### What will be the main focus of your exhibit?

Kraibon has been tested and proven for applications in the automotive and aircraft industries. Now it's time to introduce this concept to rolling stock. This uncured elastomer is incorporated directly into composites, mainly pre-pregs. The curing process for the elastomer is the same as for the resin, so no additional production process is needed. The basic requirements are a curing temperature of at least 100°C and some pressure. The advantages are improvements in acoustic, impact and splintering behaviour.

### Can you detail a recent application?

Unfortunately it isn't possible to present detailed applications, because we have signed non-disclosure agreements with most of our customers. One case we can disclose, though, saw Kraibon applied in an automotive interior for acoustic reasons. The application enabled the component to be made thinner, reducing weight (and therefore fuel consumption and CO<sub>2</sub> emissions) without acoustic disadvantages like chattering. Kraibon has also been used to improve the safety of an aircraft component. In the unlikely event that the component breaks, it won't crack into pieces, which greatly reduces the risk of injury to people nearby. A video on our website shows a similar crash test.

### How is demand evolving?

The combination of uncured elastomers with fibre-reinforced plastics (FRP) is a new

technology – so new that even most FRP producers don't know about it. But once the customer understands the benefit of this kind of composite, they will find more applications for it. In comparison with the aircraft and rail industries, the development time for automotive applications is shorter. So it's hardly surprising that the automotive industry is the strongest market for us right now. However, I wouldn't exclude the possibility that this might change.

### What challenges do you face?

It is not enough to provide our customers with data sheets and processing guidelines for our material. We also have to know all about the various production methods, FRP processing and elastomer processing. It is also a big challenge to face the requirements of different industries, for example the EN45545 standard, one of the basics for rolling stock. In response to this we ordered a test of a composite with one of our flame-retardant grades, carried out by a certified laboratory. This composite fulfilled the requirement of R1 HL2. Some other institutes were tasked with performing various acoustic, impact and splintering tests on Kraibon. Using these results, we can improve our materials even more. All this is a big investment for a family-owned company with fewer than 2,000 employees worldwide. But our management team believes in this promising new technology and the growing FRP market.

Meet the Gummiwerk Kraiburg team on **Stand 5180**

## RIGHT LIGHT

**Optis** will highlight its software solutions for creating physically correct, CAD-based light and optic simulations. It will show how innovative light concepts can be simulated and promote the idea of making light simulation an integral part of the railcar development process, from the idea to simulation to reality. Optis's services cover the whole process of light simulation – from capturing optical properties via simulation and optimisation to real-time and even virtual-reality visualisations.

The company says one of its key differentiators is that it uses physical measured material, surfaces and light sources to boost the authenticity of the final simulation. **Stand 3040**



## METAL FORMING

One of the solutions highlighted on **Ascamm Technology Centre's** stand is a dieless technology for freeforming metal sheet components such as wash basins and toilet bowls, which the company says enables total design freedom and requires no investment in tooling.

Ascamm Technology Centre will also highlight customised plastic optics devised for highly efficient, purpose/environment-specific LED lighting, and plastic moulded parts developed for specific fire resistance, strength, conductivity and abrasion characteristics. **Stand 3075**



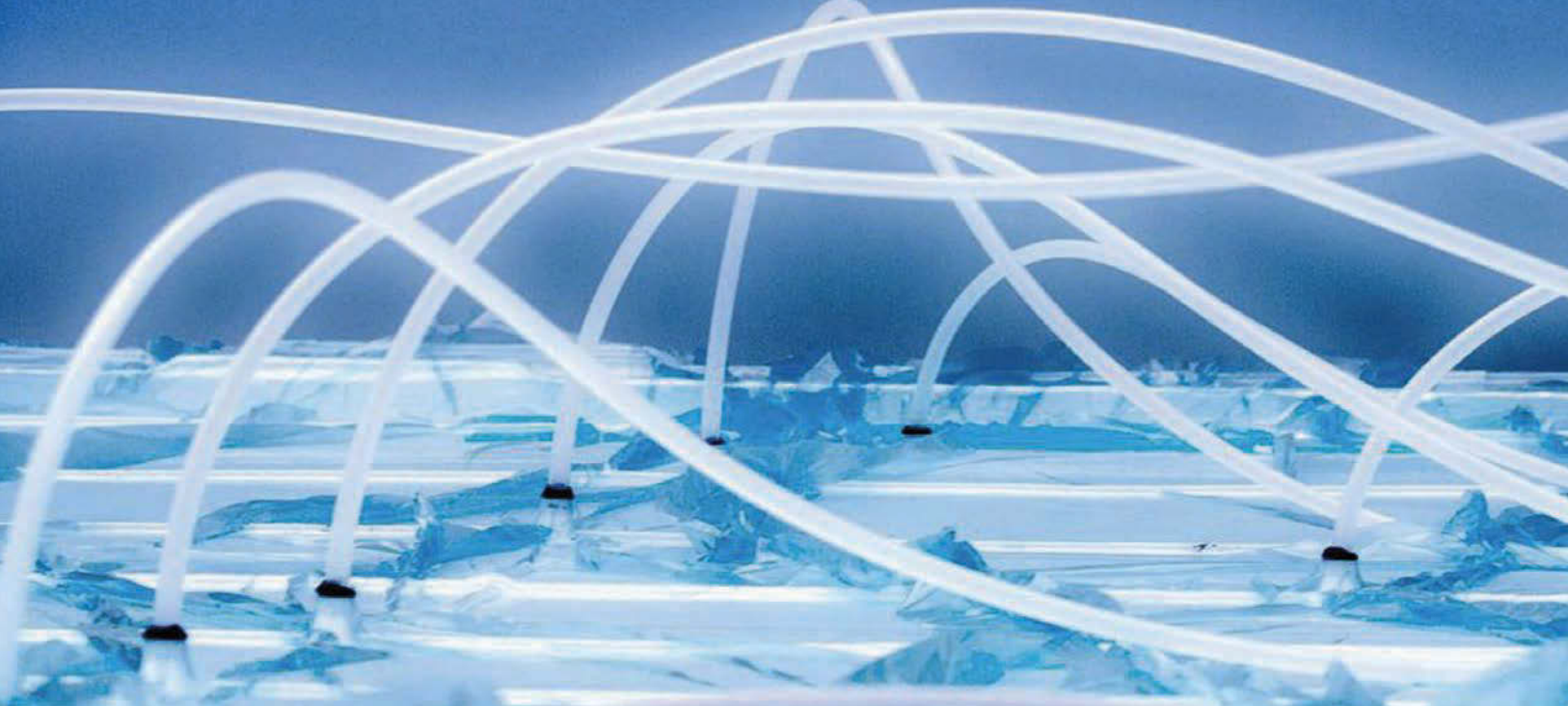

**INNOVA COMPOSITE** has set a goal of becoming sector leaders. To achieve this, it has implemented the most modern manufacturing technologies, such as infusion and RTM. In turn, we use fire retardants resins and sandwich structures systems.

**INNOVA COMPOSITE** offers the complete product cycle, from collaboration in design to final production, including in this process the manufacture of models and moulds needed. This operating route means a significant improvement in the rate of customer productivity. The development process is supervised by technicians, production and quality control managers, with long experience in the sector.

**Innova Composite makes pieces for a wide range of sectors such as caravanning, buses, construction.... Using this modern material and systems. We achieve pieces with low weight, better quality of the laminate and sandwich structures, and better fire properties.**

CONTACT US FOR FUTURE DEALS  
[www.innovacomposite.com](http://www.innovacomposite.com)



rica seats

## Comfort. Safety. Quality.

For more than 20 years, Rica Seats has excelled in design, production, assembly, installation and refurbishment of seating systems and interior components for high-speed, intercity and commuter trains.

Our core know-how in metalwork, wide experience in systems integration and flexible approach allow Rica Seats to offer a diverse and high-quality range of products in the area of rail vehical seating and interiors.

Visitors to our stand at RIE can see and try out our premier seat models.

# Anti-graffiti solutions

Your ally in the fight against vandalism!



- > AG5000 range features 86 colours
- > AG800 ultra-clear window film
- > Makes surfaces easy to clean
- > Fast product application

The **AG5000** is a high performance anti-graffiti solution consisting of a coloured 65µm vinyl film and a 36µm polyester film. Substrates covered with **AG5000** make the surface easy to clean, even when they are defaced by paint or marker pens. Any marking can easily be removed with a cloth and HEXGEL (a non-toxic cleaning gel). With the **AG5000**, you change only the damaged part and in a very short time.

The **AG800** is a clear 100µm polyester film that prevents scratches from knives and sharp tools on windows.

The use of HEXIS anti-graffiti films will turn out to be more cost effective and faster compared to painting and glass replacement.

**HEXIS S.A.**  
Z.I. Horizons Sud - 34110 FRONTIGNAN - FRANCE  
Tel. (+33) 467 18 66 80 - Fax: (+33) 467 48 38 79

e-mail: [export@hexis.fr](mailto:export@hexis.fr) | [www.hexis-graphics.com](http://www.hexis-graphics.com)







## DURABLE FLOORING

Forbo's exhibit will feature its Flotex FR flooring, which combines the aesthetic benefits of a textile floor covering with the durability and other practical benefits of vinyl or linoleum. The product consists of a densely flocked surface layer of nylon 6.6 fibres, anchored firmly into a solid vinyl base layer. Flotex FR comes in a range of patterns, colours and designs, is dimensionally stable, bacteriostatic, and boasts excellent acoustic and slip-resistance properties. The Flotex FR High Definition digital print collection, meanwhile, allows for large endless pattern repeats and vivid colours, providing design flexibility for rail environments. **Stand 3010**

## LIGHT LAVATORIES

TRB Lightweight Structures will highlight its passion for reducing weight – in rail vehicle interiors, exterior components and full product modules such as its PRM toilet module. With decades of experience in rail, aviation and industrial applications, the company's mission is to make vehicles more efficient by reducing their mass. **Stand 4100**

## SPEAKER SPOTLIGHT



**Dr Bernhard Rueger**, assistant professor at **Vienna University of Technology in Austria**, will detail his latest research project – helping rail passengers to make more efficient use of their travel time

### What is the research all about?

I have more than 10 years of experience on projects relating to passengers' needs and expectations for long-distance rail travel, especially regarding services, interiors and the transport of luggage. The Flexicoach project is about developing interior concepts that enable every passenger to easily adapt their seating area according to their needs.

### What were the key findings from your work?

The first stage of the project was to ascertain passengers' basic needs and typical difficulties encountered. We found that passengers want to use their journey time efficiently. Rail's ability to enable this is one of its biggest benefits over most other modes of travel. But each passenger has a different idea of how they would like to use the time – some want to work, others to sleep or talk to each other, and so on. This diversity throws up one of the biggest challenges. Ideally, each passenger should be able to satisfy his or her needs without impacting others on board. The study concluded that, at the moment, passengers' needs are hardly fulfilled.

### What improvements would you like to see?

One possibility would be to enable personalisation over the seating area. If the passenger could adjust the temperature, light, air-conditioning, sunshades and more, without impacting other passengers (by having noise-cancelling at each seat, for example), and if they had all the equipment they needed (to enable them to work, for example) they could maximise their efficiency. This would provide rail with a big competitive advantage over other modes of transport.

### Does the industry need to think more about passengers?

I have noticed a change in the way the rail industry thinks. Some years ago the rail industry talked about customers, and meant the rail operators. But now the focus is on the real customers – the passengers. So I'm optimistic about the future and hope to see more and more interiors that really fulfil passengers' needs and expectations – interiors in which the passengers can really be happy.

**Deutsche Bahn, Giugiaro Design and Siemens CVC will also be appearing alongside Dr Rueger at the free-to-attend Open Technology and Design Forum, held over all three days of the Expo**

## GROOVY GRANITE

**Nora Systems**, which develops, manufactures and markets rubber floors, and offers other services, for customers around the world, will highlight Noraplan Unita – a rubber floor covering that integrates real granite chips. Designed for a subtle, sophisticated look, the product won a red dot design award in 2012. **Stand 2020**



## COAT TALES

**HSH Railway Finishes** will focus on its Intercoach water-borne coating system, which consists of cleaners, degreasers, fillers, primers, top coats, touch-up markers and speciality products. The company says the coatings are extremely fast drying, show great mechanical and chemical resistance, and exceed the flammability requirements.

HSH also says it offers solutions for virtually any substrate, and boasts compliance with international standards including BS476-6 and EN45545-2 (more qualifications are in progress). The company supports OEMs, manufacturers, maintenance companies and operators on new-build and refurbishment projects, and offers a 48-hour lead time. Any colour from many standards can be produced, and any sample can be custom colour-matched.

HSH also offers several services – a full package whereby it sends the paint and the painters to the customer; in-house painting at its base in Belgium; and training, consulting and other expertise.

The company was founded in 1986, and focused on the aircraft interior industry for its first 20 years, before expanding into the rail market. Customers include SNCB/NMBS (Belgium), PRASA (South Africa) and VIA Rail (Canada). **Stand 1055**

FULL-SIZE  
MOCK-UP

## GREAT DANE

**Oliva Torras's** railway department will showcase examples of pre-preg composite materials applied in modern railway interior designs – including a full-size scale model of the interior design

for Copenhagen's automatic light metro, currently under production.

Pre-preg materials made from phenolic resins and glass fibre enable the manufacture of complex parts with an excellent finish on

both sides, which also boast great strength and lighter weight.

The company will also present its railway interior design services, spanning integrated engineering to turnkey projects. Based in Manresa, near Barcelona, the Oliva Torras Group works in sectors as diverse as motorways, car parks, renewable energy, leisure and refrigerated transport. **Stand 5080**





## COMPLIANT PLASTICS

**Cox Wokingham Plastics Limited** (CWPL), one of the UK's largest plastic thermoforming specialists, is gearing up to offer plastic interiors for train operators and manufacturers for the first time in 25 years. The company says it is well positioned to capitalise on a new flame-retardant thermoplastic sheet, which meets the new EN45545 European safety standards. The UK rail industry has adopted this standard in Hazard Levels 1 and 2 classes. As a result, CWPL will offer plastic mouldings for seats, tables and sidewalls, pillar cappings and ceiling panels for rail carriages and tram interiors.

The company believes this material offers cost benefits and is up to 20% lighter than the standard metal and GRP, conserving fuel and reducing CO<sub>2</sub> emissions. A range of textures and colours are available, as well as the option to create bespoke colours in line with corporate identity guidelines.

CWPL has built up a reputation for producing high-definition mouldings, and the assembly and machining of components for demanding markets such as the rail, aircraft, bus and coach industries, as well as the commercial industrial lighting, medical and automotive sectors. **Stand 6050**

## EXHIBITOR IN FOCUS



**Teresa Burguillo Lozano**, general manager at **Innova Composite**

### What is going to be the main focus for you at the exhibition?

Our main reason for participating is to open up the railway market, as we believe that we can import production systems that are used in other sectors, including shipbuilding and construction. We specialise in making parts that are highly fire-retardant and very low in weight, using systems such as resin transfer moulding and infusion, with new fibre and cores. This is our main advantage over our competitors.

### Can you detail a recent project?

Our latest task was to make parts for a building's façade, in line with the Bs3d2 fireproofing requirements, which are much more demanding than in the rail industry. For this we used the infusion system, which, in conjunction with using materials such as resin, enabled us to meet the fireproofing requirements while achieving a very low weight. These parts are made of sandwich systems, so the final piece has high stiffness and low weight.

### What are your plans for the future?

We are aware of the importance of weight on trains and think we can help in this area, using the knowledge and experience we have gained in other sectors. Our goals are to consolidate in the sectors in which we already have a presence (such as the wind, bus and marine), start our journey in new sectors (such as rail) and continue to develop new systems and applications for composites. Although we are a small company, we believe in the importance of research and development, so we continue to invest in this area.

Meet the Innova Composite team on **Stand 5120**

## CUSHION FOAMS

Although **Rogers Corporation** offers a variety of materials for the rail industry, its focus at the show will be Bisco MF1 seat cushion foam. This silicone seating material was developed to be lightweight, flame retardant and easy to fabricate. MF1 foam is guaranteed for 10 years and is designed to meet global flame, smoke and toxicity standards without sacrificing durability or comfort. In fact, this material is already being used in many railway seating applications worldwide, from San Francisco to New York to Taiwan.

Also, for those seeking a lighter though no less durable material, Rogers has recently launched Silfx comfort foam, a top pad material designed to increase comfort and decrease weight. Rogers developed this non-petroleum-based silicone foam to enable thin cushion design, longer life and lasting passenger comfort. The company sums up Silfx comfort foam as a low-density flame-retardant silicone that can easily be incorporated into many seat designs.

**Stand 4040**



## SEAT COVERS

As well as showing the 3D Moquette fabric, **Fuchi Textile** will highlight its use of recyclable PET in a variety of seat cover fabrics, the aim being to minimise the environmental impact. Compared with wool, Fuchi contends that PET is cost-competitive and doesn't compromise on aesthetic appeal, anti-flammability or safety guarantees. A new, lightweight but highly durable moquette will also be shown. **Stand 4120**

## VINYL REVEAL

**Omnova Solutions** will showcase its PreVaill Transit upholstery product with PreFixx protective finish, which has been engineered to meet the rail industry's demanding flame, smoke and toxicity requirements for mass-transit seating.

The company states that PreFixx lends the vinyl upholstery excellent durability and chemical resistance, and makes maintenance easy because most common stains simply wipe off. The upholstery can also be disinfected with many standard chemical cleaners without discolouration or damage to the finish. PreVaill Transit is available in stock and custom designs, colours and textures. **Stand 6005**



# Rail Interiors Solutions

A one stop shop for your rail interior needs

textiles  
Scotland

[www.textilescotland.com](http://www.textilescotland.com)

A cluster of forward-thinking Scottish companies has joined forces to offer railway operators a one-stop shop for train carriage interiors, and will promote the new offering at the show.

Together, the consortium of five companies aims to offer all the expertise and materials required to transform a carriage from an empty shell into a modern, attractive and comfortable environment for passengers travelling in any class, from standard to luxury.

Visit us at Stand Number 3015 at the Railway Interiors Exhibition in Cologne from 12 -14 November 2013 and find out how we can help you.

[www.railinteriorsolutions.co.uk](http://www.railinteriorsolutions.co.uk)



Muirhead®  
HIGH PERFORMANCE LEATHER

forbo

FLOORING SYSTEMS



novograp  
rethink | renew | rebrand

Replin

TRANSCAL  
Inspiring interiors

[www.muirhead.co.uk](http://www.muirhead.co.uk)

[www.forbo-flooring.com](http://www.forbo-flooring.com)

[www.novograp.co.uk](http://www.novograp.co.uk)

[www.replin-fabrics.co.uk](http://www.replin-fabrics.co.uk)

[www.transcal.co.uk](http://www.transcal.co.uk)





Industrial design and engineering of new and refurbished rail vehicles

Branch Hill Mews London NW3 7LT | +44 (0)20 7435 1777 | [www.atlanticdesign.uk.com](http://www.atlanticdesign.uk.com) | [enq@atlanticdesign.uk.com](mailto:enq@atlanticdesign.uk.com)

individual  
seating systems  
for people  
on the move

**kiel**

**COMFORTLINE**  
INTERCITY TRANSPORT

[www.kiel-sitze.de](http://www.kiel-sitze.de)

FRANZ KIEL GMBH ■ Nürnberger Str. 62 ■ 86720 Nördlingen ■ Germany



## FIRE APPROVAL

**BRE Global** will promote LPCB, its approvals brand for certification of fire and security products and services. Based in the UK, the LPCB approval mark is recognised widely around the world and was established to provide regulators and end users with confidence in the products and services they choose. Full listings are given in the LPCB Red Book and can also be found online.

Operating in some of the world's most extensive fire laboratories, BRE Global offers fire resistance and reaction-to-fire testing and has UKAS (ISO 17025) accreditation for a wide range of tests, including EN 45545:2013 fire protection of railway vehicles. The company reports that its test labs are endorsed by the Certifier Rail Certification Agency.



Capabilities include the full range of reaction-to-fire testing for materials and components specified in EN 45545-2 Part 2, including smoke and toxicity testing (ISO 5659-2) using gas analysis by FTIR, spread of flame testing to ISO 5658 2 and cone calorimeter testing for heat release rate to ISO 5660 1.

BRE Global most recently took part in the EU Transfeu project and continues to contribute to development of the tests on railway seats and combustion product toxicity. **Stand 4180**

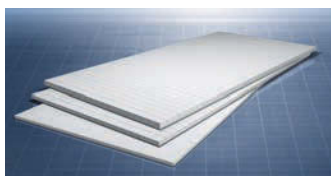

## FOAM FAMILY

**Armacell** will show its structural PET foam core family, ArmaForm PET. The range includes ArmaForm PET FR, which the company says has been certified in accordance with transport flame, smoke and toxicity standards, including NF F 16-101 and DIN 5510 with classification M1/F1. It is also designed to offer an optimised strength-to-weight ratio, outstanding fatigue and corrosion resistance and big weight savings. Armacell says that ArmaForm PET's thermoplastic basis means it can be easily thermoformed into complex shapes; its good screw retention and adhesive bonding characteristics facilitate assembly and joining of PET composite parts; its insulation properties improve energy efficiency; and its 100% recyclable nature reduces the operator's ecological footprint. **Stand 7090**

## DOUBLE DEBUT

NEW LAUNCH

As well as a number of components manufactured with its composites materials, **Cytec** will showcase two new resin pre-preg systems developed to meet the EN45545-2:2013 fire requirements. The first, MTM348FR, is a curing epoxy resin pre-preg matrix offering HL2 protection, which is ideal for the manufacture of lightweight composite components for both interior and exterior structural and non-structural applications.

The second product, in development, is XMTM30. Cytec says this is produced from a bio-renewable source and meets the fire requirements of HL3; it is particularly suitable for the production of non-structural interior components.

Cytec's epoxy and phenolic resin pre-pregs enable the manufacture of thin and complex sections, including sandwich panels. Typical rail interior applications include wall panels, window frames, partitions, connecting archways, floors, ceilings, standbacks, luggage racks, seats and doors. All Cytec's pre-preg resin systems are suitable for use with most formats and substrates, including woven and unidirectional carbon and glass. **Stand 8060**

## SPEAKER SPOTLIGHT



**Dr Joachim Winter**, a senior scientist at the **German Aerospace Center (DLR)**, will present the Next Generation Train (NGT) concept, for which he is project manager

### What is the NGT?

The NGT is a research project by the DLR, which was founded by the German government and reviewed for quality every five years by Helmholtz Association of German Research Centres. The objective is to focus all the DLR's research on railway vehicles. Since 2007, 11 of the 32 DLR institutes have contributed. The latest review, in April 2013, earned us a rating of 'excellent', so the project was extended until 2018, and the number of researchers boosted by 60%. The key aim of the NGT is to reduce travel times and develop an environmentally friendly railway vehicle. To achieve this, we created an ultra-high-speed train (NGT HST) running at 400km/h, and a high-speed feeder train (NGT Link) running at 230km/h. Both are double-deckers, accommodating 800 and 580 respectively. Energy consumption is reduced by 50% per seat compared with existing HST trains. The trains also had to be attractive to passengers.

### What routes could these trains run on?

Together these trains would provide a hub-and-spoke system to reduce travel times for a large number of passengers. The NGT HST is for ultra-high-speed lines with only a few stops; the NGT Link would feed people from the surrounding area to the HST stops, so it would serve the smaller stations. The NGT Link has a hybrid power supply, so it can also run on non-electrified lines, which eliminates having to change from electric to diesel locomotives – we want to avoid diesel completely.

### What's next for the NGT?

The third phase of the project, which runs until 2018, will deal with passenger comfort in terms of air-conditioning, air pressure, noise and seat access. This kind of research will be extended to the duties of a driver on ultra-high-speed trains. We will also derive methods to calculate transient aerodynamics and vehicle crashworthiness; investigate cross-wind stability; and develop the mechatronic single-wheel single running-gear, inductive power transmission and remote coupling of train sets.

The **Open Technology and Design Forum** is brimming with interiors expertise, with presentations confirmed from **MBD Design, PriestmanGoode and Seymourpowell** to name just a few

## CUSTOM MADE

One of **Treadmaster's** flooring products has been specified as part of the successful design of the New Bus for London, created by Heatherwick Studio. The initial designs were integrated into its Treadmaster TM3 grade, which is well established in the bus and rail markets and will be shown at the Expo. A new service will also be promoted whereby clients can provide specific designs, company names or logos to be created or inserted into the flooring. A way of printing designs onto floor surfaces is also being investigated, giving rise to the possibility of creating special effects and images. In fact, Treadmaster is currently working with several UK and European design houses on projects where a specific design is required to create a personalised image for end users. **Stand 3090**



**FREE TO ATTEND!**

# OPEN TECHNOLOGY AND DESIGN FORUM HIGHLIGHTS

The Open Technology and Design Forum is a unique feature of **Railway and Mass-Transit Interiors Technology and Design Expo**, providing attendees with a three-day conference with top international speakers giving an insight into new product and service innovations and case studies. The free-to-attend presentations deliver content and great value to the event, and many seats are reserved well in advance. Here are just some of the highlights:

## MAINSTREAM CONFERENCE

### DAY 1, TUESDAY 12 NOVEMBER

#### High-speed train interior engineering experience

*Alberto Fumagalli*, business unit director, Giugiaro Design, Italy

#### Redesign of ICE- and IC-fleet of Deutsche Bahn: a challenge in terms of time schedule and quantity

*Dr Uwe Weiger*, head of workshop, DB Fahrzeuginstandhaltung GmbH, Germany

### DAY 2, WEDNESDAY 13 NOVEMBER

#### Possible business models for onboard systems for high-speed trains

*Dr Francesco Prato*, director, Siemens CVC, Austria

#### A vision for connected fleets over the next five years

*Jay Saw*, business development director, Nomad Digital Ltd, UK

#### Keeping the passenger better informed and entertained during transit

*Jenny Brown*, sales manager, Icomera UK Ltd, UK

#### Commercialisation and ancillary revenues from digital content

*Rick Stuart*, CBDO, Adaptive Channel SAS, France

### DAY 3, THURSDAY 14 NOVEMBER

#### The weight reduction revolution in rail has arrived

*Robert Hodgson*, director of sales - rail, TRB Lightweight Structures, UK

#### Converting thermoset to thermoplastic interiors for weight reduction/sustainability

*John Zerillo*, VP/principal, Productive Plastics Inc, USA

## BREAKOUT SESSIONS

### DAY 1, TUESDAY 12 NOVEMBER

#### Delivering a new UK commuter seat in six months

*Paul Rutter*, transport manager, DCA Design International Ltd, UK

#### Influencing train interior comfort expectations by design

*Prof Peter Vink*, Delft University of Technology, Netherlands

### DAY 2, WEDNESDAY 13 NOVEMBER

#### The effect of surface materials on the progress of a fire

*Anna Bergstrand*, project manager, SP-Technical Research Institute of Sweden, Sweden

#### Quantifying train fire hazard into maximum fire sizes and toxicity

*Andrew Coles*, senior engineer, Sereca Fire Consulting, Canada

### DAY 3, THURSDAY 14 NOVEMBER

#### Advances in lightweight composite pre-pregs and the challenges of EN45545

*Dr Richard Horn*, rail market sector manager, Cytec Industrial Materials, UK

#### Lightweight UP structures fulfilling EN 45545

*Paul Wartenweiler*, BU manager composites, Walter Mäder AG, Switzerland



\*This programme may be subject to change

View the full programme at [www.railwayinteriors-expo.com](http://www.railwayinteriors-expo.com)



The latest and next-generation railcar and mass-transit design, materials and technology showcase!

image: © SCHOTT AG

# Railway & MASS TRANSIT interiors

TECHNOLOGY  DESIGN

**EXPO 2013**

**FREE TO ATTEND!**

**100+**  
EXHIBITORS  
EXPECTED!

# YOU NEED TO ATTEND THIS SHOW!

**12/13/14 NOVEMBER 2013**  
KÖLN MESSE, COLOGNE, GERMANY

**PLUS:** Featuring  
the largest  
free-to-attend  
railcar interiors  
conference ever  
to take place!

#### WHAT'S ON SHOW

Interior concepts / Composites / Interior refurbishment / Replacement parts / Seating / Fabrics / Floor coverings / Laminates / Safety equipment / Lighting / Galley equipment / Comfort products / Luggage racks / WiFi and communication systems / Refrigeration / Electronic displays / Food service equipment / Electrical and power management devices / Washrooms and restrooms **and much more...**

UKIP Media & Events Ltd, Abinger House, Church Street, Dorking, Surrey, RH4 1 DF. Tel: +44 1306 743 744 Email: [damien.deroche@ukip.me](mailto:damien.deroche@ukip.me)

**Register online: [www.railwayinteriors-expo.com](http://www.railwayinteriors-expo.com)**



# Fast forward

On projects such as Amtrak's new LDSL cars, the range of RailPlan's in-house capabilities is enabling it to push for innovation

**W**ith expertise spanning consulting, engineering, manufacturing, industrial design and mechanical services, RailPlan International has the capabilities to take a project from concept through production and beyond.

With its headquarters in Baltimore, Maryland, USA, the company's dedicated staff develop both turnkey products and complete railcar interiors. Its Mechanical Services division, meanwhile, provides rolling stock maintenance for several passenger rail operators. Combined, this specialist know-how enables it to service a railcar throughout its entire lifecycle.

RailPlan is also a representative to the US Access Board's Rail Vehicles Access Advisory Committee and is an integral resource in the revision of the rail vehicle portion of the transportation vehicle guidelines. These provide specifications designed to ensure the industry as a whole accommodates all passengers' needs into designs. The company is similarly involved in PRIIA, APTA and the Buy American programme, to enhance the quality of passenger experiences in the USA, as well as support the national economy.

**MAIN:** The 'Roomette' on Amtrak's CAF-built LDSL railcar

Having worked with many industry-leading manufacturers and rail authorities, RailPlan's Mechanical Services division is currently working alongside service providers in three US states: the Maryland Area Regional Commuter, the Virginia Railway Express and the North Carolina Department of Transportation's Rail Division.

## Experience counts

Including procurement as well as management of rolling stock, warehouses and facilities, the company ensures full Federal Railroad Administration compliance as well as car and locomotive maintenance. Its manufacturing and consulting projects have included individual components, full remanufacture and complete new interiors. Past successes include producing full-scale mock-ups for Nippon Sharyo's new DMU and developing the interior and exterior of Southeastern Pennsylvania Transit's Silverliner V.

Another such project is based around Amtrak's order to carbuilder CAF for 130 new Long Distance Single Level (LDSL, formerly known as Viewliner) cars. With a remit to design, engineer





and manufacture fully modular interiors, RailPlan is the largest single vendor to the project. The interiors consist of 'Roomette', 'Deluxe' and ADA-compliant bedrooms; restrooms and showers; full galleys; and complementary products such as occasional seats. Throughout the development process, RailPlan coordinated with multiple departments within Amtrak – including onboard services, catering, marketing and maintenance – to ensure the best possible design.

This intense effort led to major improvements for the interior and exterior designs, a prime example being the creation of a more user-centred galley. Through a process of soft and hard mock-up reviews and iterations, Amtrak galley employees were able to provide direct input to RailPlan designers to ensure the space maximised their capabilities. This user research approach continued with the ADA community's involvement in incorporating enhancements over the previous generation of cars, such as the expansion of the ADA bedroom space through elements such as a curved powered door.

To fulfil the complement of sleeper, baggage/dorm and diner cars, a high level of integration was required, not only between development and production staff but also between the room modules and the carbodies (including systems) that CAF is manufacturing. RailPlan attributes its success on this complex project to the close relationship between its development and production divisions. Every aspect of the design can be transitioned from paper concept to 3D CAD-rendered part to final product under the same roof, enabling staff to interact in person to ensure that

**ABOVE LEFT:**  
The LDSL's galley

**ABOVE RIGHT:**  
The luxurious dining area in the LDSL car

**BELOW:**  
Business-class seating on RailPlan's Corridor Capital Bi-Level project

every detail is realised accurately. It also enables direct analysis of each product by RailPlan's quality-control staff and clients.

The prototypes of all four car types are now either in the final stages of construction or entering the testing phase. RailPlan is also now producing galleys and room modules.

### User-centric approach

With each project it has undertaken, the company has grown and pushed itself to innovate. Its focus is to provide not only cost-effective, quality products but to create a true user experience through design. With modern factors such as LED lighting, thermoformed parts, fibreglass-reinforced plastics and safer fabric options, RailPlan has worked with its suppliers to advance the passenger rail industry's overall effect on the rider's journey.

The rail specialist also looks to innovate with the development of its own engineered projects and products. "These utilise thoroughly crafted and extensively tested systems to provide the user with consistent service," says Terry Soesbee, president at RailPlan. "A 2011 Brunel Awards recipient and part of Amtrak's Superliner overhaul, RailPlan's ADA-compliant bathroom modules embody this effort of top-level grade and create the industry standard for full-access onboard service."

The company's engineered product line, consisting of in-stock fully developed systems, includes solutions such as its emergency evacuation bridgeplate and gangway/diaphragm. The latter is in the process of being retrofitted across Amtrak's entire fleet, and was designed to be safer, more cost-effective and feature longer-lasting components. RailPlan hopes such efforts will provide a way to create modern, more reliable railcars, whether new or refurbished.

"Whether maintaining regional rolling stock, helping to update vehicle guidelines, or manufacturing complete interiors and turnkey products, every effort is made to advance the passenger rail industry," Soesbee says. "Innovation, quality and more than 25 years' experience drive every aspect of our capabilities." ☒



### CONTACT

tsoesbee@railplan.com; www.railplan.com

# As good as new

With its proposal for Eversholt Rail Group's Mark IV intercity rolling stock, Atlantic Design Projects provides a model for value-adding refurbishment

In December 2011, Atlantic Design Projects was appointed by UK leasing company Eversholt Rail Group to generate design proposals for the upgrade and enhancement of its fleet of 30 Mark IV intercity train sets currently operating on the UK's East Coast Mainline. Built in the late 1980s, these electric trains form the backbone of the high-speed service between London and Edinburgh. While these trains underwent a major refit in 2005/2006, Eversholt Rail's brief to Atlantic was to explore the 'art of the possible' and this later became the strapline for a series of mock-up presentation events around the UK.

Key elements within the vehicle interiors were identified for a complete redesign, focusing on passenger comfort and visual appeal, capacity increase and vehicle weight reduction. The overall strategy was to target investment and design emphasis to reinvent these trains, making them a highly attractive and cost-effective alternative to new trains.

An all-new standard-class seat design was created by Atlantic in conjunction with Finnish manufacturer Rica. This ultra-slim seat has a single formed sheet of aluminium honeycomb forming both its structure and outer shell, and silicone cushions that can be cut from slab stock rather than requiring mould tools. It is configured as a mini sofa – which Atlantic says weighs 40% less than the existing standard-class seat pair – with a consistent profile across the two seat places. This means the seats can be used in a variety of ways – two passengers can use the seat in a conventional manner of course, but stowing the central armrest allows, for example, a parent and two smaller children to sit together comfortably. The design, with a continuous 1,050mm-wide cushion, also targets a feeling of spaciousness, and anticipates a need to accommodate larger passengers.

Atlantic used natural materials such as sustainably produced leather and real wood veneers to add a sense of luxury to the seat. Equally, the durable leather covers and the shape of the seat were used to facilitate efficient cleaning and ease passenger access.

The seat has been designed to meet the UK's demanding crashworthiness requirements, while the headrest design reduces visual mass at the top of the seat, helping to maintain a feeling of light and space within the saloon. The slim seat profile saves 15mm of saloon length per seat row and 25mm per seat bay compared with the existing Mark IV standard-class seat. These savings can be used to provide more storage for luggage, additional facilities or more passenger space.





RIGHT: The first-class seats have a deeper cushion and winged leather headrests

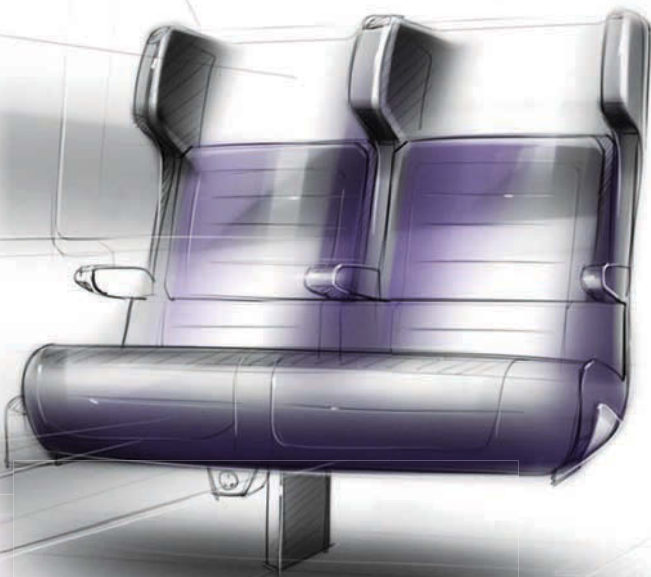

Atlantic Design advocates the use of the same seat in business class. However, here all seats will be configured at first-class seat pitch, in bay arrangements around a 700mm-side table, allowing for the use of four large laptops at each table. A variety of power sources are provided for each passenger, including a conventional socket, USB charging ports and inductive charging. It is envisaged that during non-peak business-class periods, for example weekends, the business-class section could be redesignated for family travel.

The trains feature automatic LED lighting throughout, introduced to reduce maintenance and provide a cleaner and more consistent appearance. The lighting system is automatically self-adjusting, saving energy when lower lighting levels are required. In first class, the side ceiling washlights feature RGB LEDs to provide subtle moodlighting, which can be enhanced with washlights at floor level or feature lighting integrated into elements such as the tables.

Other elements of the first-class design engender an altogether different experience from that of standard class. While the seat design is similar, with the wide sofa cushions having a uniform profile, the seats are much deeper, with winged leather headrests and soft cotton pillows to provide more privacy, comfort and luxury.

### Information stations

One of the most interesting aspects of Atlantic Design's proposal is the passenger information system, and in particular the at-seat reservation (ASR) system. ASR features large, full-colour TFT screens and a traffic-light status indicator at each seat place. This system enables boarding passengers to quickly identify which seats are likely to be available. Atlantic hopes it will reduce anxiety for passengers and reduce station dwell time during peak times at intermediate stops. The reservation status of each seat can be updated in real time, and the colour and brightness of the screens change, becoming active as the train enters a station and for up to five minutes afterwards, making the information even more visible and accessible to boarding passengers. This system, together with the large full-colour general passenger information screen system, is being developed in a partnership between Eversholt Rail, Belgian supplier Televic Rail and Atlantic Design.

These and a number of other design ideas for upgrades and enhancements to the Mark IV fleet were showcased at presentation events in London, York and Edinburgh in late 2012 and early 2013. The centrepiece of these events was a full-size, 13m-long mock-up supplied by Atlantic Design. The events were attended by a wide range of invited guests from the UK rail community, including the Department for Transport, Transport Scotland, train operating companies, passenger representatives and train crew. Feedback from this stage of the development process has been collated and reviewed by the team at Atlantic Design and Eversholt Rail.

Based on this structured, phased design process, refinement of the Mark IV proposals is ongoing. Atlantic Design reports that a number of train operators across several franchises have shown keen interest in the fleet, so it remains crucial that design flexibility is retained. Whatever their future, it seems that the Mark IV intercity vehicles still have much to offer. ☺

LEFT: The sofa-style standard-class seating is covered in durable leather

BELOW: Highlights in business class include large tables with inductive charging



### CONTACT

og@atlanticdesign.uk.com; www.atlanticdesign.uk.com



# Firm foundations

Rubber floor coverings from Tiflex have found particular favour with metro operators - from London to Singapore

**U**nder the Treadmaster brand, Tiflex has been creating slip-resistant and fire-retardant rubber floor coverings for buses and trains since the 1950s. A key selling point is that the company's main railway flooring products are all PVC-free.

Tiflex's flagship product is TM7, which is produced in both flat and profile surfaces. "This product achieves excellent results for smoke, spread of flame and toxicity, when tested to UK (BS 6853), French (NFF 16-101) and US (NFPA 130) standards," says Barry Curtis, sales manager for flooring at Tiflex.

TM7 has been chosen by many metro operators - including RATP in Paris, France; MTR in Hong Kong, China; and SMRT in Singapore. In fact, Tiflex has won multiple TM7 contracts for the SMRT. The first of these, in 2000, was awarded by the Land Transport Authority in Singapore and involved working with OEMs Kawasaki and Nippon Sharyo for 21 new six-car trainsets. "TM7 was specified on the basis of its fire- and slip-resistant properties," says Curtis. This was followed in May 2010 by a contract with Sifang (part of CNR CRC, based in Qingdao, China) for 22 new six-car trainsets, with a further contract in November 2012 for an additional 13 new six-car trainsets.

Tiflex also won a refurbishment contract for the SMRT in 2008 - the company was chosen by Hyundai Rotem Company to supply floor coverings, adhesives and sealant for 396 of SMRT's C151 cars. These deliveries began in November 2008, with trainsets initially supplied at intervals of six weeks, speeding up to one a fortnight. The final of these was handed over in May 2013.

Some of the trains running on the UK's London Underground also feature TM7 flooring. Tiflex was awarded its first contract for the London Underground in 2004, to supply TM7 based on Bombardier's specification for the refurbishment of 198 cars used on the District Line. This continued with contracts for 376 Victoria Line cars, 1,395 subsurface cars and 216 London Overground cars. The company is also currently supplying TM7 for the refurbishment of 636 Piccadilly Line and 516 Northern Line cars.

"At the start of each project, we work with the OEM and sometimes the operator, providing different colour options and widths - the latter so we can minimise waste by determining the optimum size," explains Curtis. "Adhesives and sealants are provided as part of the package. These complement our flooring while maintaining the fire performance required. We are also involved with the fitting of the first trainsets to ensure that the right procedures are in place before the main work commences."

Most recently the company has been working on the flooring for the new London Routemaster bus designed by Heatherwick Studio and built by Wrightbus in Ballymena, Northern Ireland. "The design required a number of different parts to be machined," says Curtis. "It showcases our ability to meet the specific requirements of the designer, OEM and operator." ☺

**CLOCKWISE FROM MAIN:** TM7 flooring installations in Singapore, Hong Kong and London

## CONTACT

bcurtis@treadmasterflooring.com; www.treadmasterflooring.com



Fire Retardant • Non Toxic • Hard Wearing • Slip Resistant  
Full Homogeneous • Easy to Clean • Repairable

*Some of the benefits of choosing treadmaster flooring*



**treadmaster**  
flooring

Treadmaster Flooring  
Tiflex Ltd  
Tiflex House  
Liskeard  
Cornwall  
PL14 4NB  
United Kingdom.



# Public image

Replacing conventional paint systems with wrap films can enhance a train's image and save money, contends Hexis

**T**he use of self-adhesive films as an alternative to paint and powder coatings for passenger vehicles has gained momentum as operators respond to the evolving threat of graffiti – which has latterly seen vandals using aggressive paint strippers and corrosive acids. So says Hexis, which offers a wide range of anti-graffiti and surface protection films for the transport industry. AGLR, for instance, is a pigmented latex film with polyester over-laminate that doesn't contain any PVC or plasticisers. HX100/PGR836, meanwhile, is a printable PVC film with polyester over-laminate, which was developed to offer most of the performance properties of the AGLR film yet at a slightly lower cost. And the AG5000 series is a pigmented PVC film with polyester over-laminate, developed specifically for the rail industry.

Hexis says the first two of these products are especially notable for their resistance to spray paints, marker pens, paints, pigments and corrosive acids in excess of 15 cycles of application and removal. Additionally, they resist mild solvents for up to 24 hours and the strongest paint strippers for up to seven hours.

**MAIN AND INSET: A special film treatment for the 30<sup>th</sup> anniversary of the TGV**



As far as the all-important weight considerations go, Hexis calculates that AGLR is up to 31% lighter than comparative paint systems, and HX100/PGR 836 film is up to 18% lighter. The company also says AGLR offers one of the lowest overall fire risk ratings, even when applied on top of existing paints and powder coatings, making it particularly attractive for underground and subsurface metro systems and tramways.

## Application

Many of the advantages of Hexis films are related to the way they are applied. Because they are supplied ready to use, trained applicators need only to prepare the surface, remove the adhesive backing and smooth the film onto the surfaces. Moreover, the vehicle does not have to remain on the production line while the adhesive is curing. "Consequently, the production time and costs are considerably less than those for paints, which require extended periods of time on the production line for the spraying and curing processes," says Martin Kugler, corporate communications manager at the company. "Two-



Hexis films combine visual communication and surface protection

## ABOUT THE COMPANY

Hexis is a major manufacturer of self-adhesive films and digital printing media for large-format inkjet printing used for sign making, vehicle marking and surface protection.

The company specialises in pressure-sensitive, adhesive-coated thin plastic films and created its own method to produce cast vinyl films.

The group's head office and manufacturing facilities are located in France, with subsidiaries in the USA, Germany, Italy, Spain and Sweden. Hexis exports almost 50% of its sales to some 50 countries worldwide. Its quality management system is ISO 9001:2008 certified.

pack paint systems have to be mixed while powder-coated panels are produced and cured in a separate facility, so subsequently require mounting on the vehicle production line."

Time saving is a key advantage for customers. "The result was we found a material that matched all our criteria and enabled fast application times, meaning train downtimes could be minimised," reveals James Waldron, ambulance and performance fleet manager for London Underground.

In the event that sections of Hexis film need to be replaced, trained applicators (the original vehicle builder, the service operator or other suitable contractor) can follow a removal and reapplication process that Hexis describes as simple and cost-effective. "Conversely, the replacement of painted or powder-coated areas requires the full removal of the existing coating by abrasion, followed by sprayed application and curing of the new section of coating," continues Kugler.

Hexis contends that its AGLR and HX100/PGR836 products' ability to offer reduced labour costs, downtime and maintenance translates into a 60-80% cost saving over conventional coatings.

A further benefit is that these films require only light abrasion of the surface to provide a key for the adhesive. They also don't feature isocyanate compounds and negate the need to prime aluminium and steel with chemicals, or employ special procedures or equipment to deal with solvent emissions during the application process. While there are small residual amounts of solvent in the adhesive, the quantity released is "negligible", says Kugler. "All these factors reduce health and safety risks."

Hexis also believes its films offer a more consistent quality of



## INTERIOR APPLICATIONS

The AGLR series film contains no polyvinyl chloride and can therefore be used for both the interior and exterior of trains, trams and buses, offering consistency of design.

For indoor areas, where hygiene and health concerns are of prime importance, Hexis offers an antimicrobial film. The clear film can be applied to almost any interior surface and is designed to provide round-the-clock protection against bacterial growth for up to five years.



ABOVE: These anti-graffiti films help TOCs maintain public perception of their assets

BELOW: Hexis's AGLR film offers an exterior alternative to paint

surface finish. "The orange peel effect that is often observed after application of paint and powder coatings is not only aesthetically undesirable; it also makes them less resistant to graffiti," notes Kugler. "The methods used in the manufacture of Hexis films ensure that a top-quality finish is achieved at all times."

### Aesthetic appeal

The anti-graffiti films offered by Hexis can be manufactured in two ways. If operators require a solid colour, colour-stable pigments are incorporated into the film – this is the most durable option. Those wanting more complex graphics – to incorporate advertising or complex corporate identities, for example – can specify printed graphics, whereby colour-stable inks are printed onto the film.

"The driving force for using this material was the need to change image and public perception of the London Underground as well as how we operate our business," concludes Waldron. "With clean and attractive-looking trains, public perception rises and confidence appears. So our ridership numbers go up exponentially with this image enhancement." ❌



### CONTACT

[martin.kugler@hexis.fr](mailto:martin.kugler@hexis.fr); [www.hexis-graphics.com](http://www.hexis-graphics.com)



# Flexible friend

An elastomer compound developed by Gummiwerk Kraiburg can optimise the advantages of FRPs

**F**uelled to an extent by the CO<sub>2</sub> debate, there has been a noticeable trend towards fibre-reinforced plastics (FRP). Thanks to their outstanding stability-to-weight ratio, they're an essential ingredient in motorsport and aviation and are gaining ground for large-series runs in mass transport and automotive.

"Although the cost of FRPs still remains a drawback, other hurdles associated with the nature of the material also need to be overcome," believes Florian Plenk, from Germany-based Gummiwerk Kraiburg. "With FRPs, for example, the forces are absorbed by fibres, which in turn are fixed and protected by a resin. Although this works very well in the direction of the fibre orientation – especially in the case of carbon fibres with very high tensile strength – in a transverse direction the fibres break relatively easily." Plenk explains that this results in a component that boasts high levels of safety but at an increased price and weight.

Gummiwerk Kraiburg has developed an elastomer compound that can easily be integrated with FRPs (using existing manufacturing processes), to reduce these disadvantages. "Kraibon consists of non-cross-linked rubber foils that contain no fibres and can be processed similarly to a pre-impregnated composite fibre and in the joint-curing process produces an excellent bond with the FRP," Plenk reveals.

**MAIN:** FRPs offer both stiffness and low weight  
**BELOW:** The effect of an impact on an FRP component without (top) and with (bottom) Kraibon

The acoustic properties of FRP components in particular can be enhanced. When integrated directly within the layer structure, constrained layer damping can be used to achieve excellent sound attenuation with very little extra weight – 500g/m<sup>2</sup> of Kraibon integrated in the layer improves acoustic damping (measured in tan delta) by a factor of 10-15. Together with a virtually unchanged production process, Plenk says this reduction has great potential for manufacturers of indoor panels and floor segments.

Another application is impact protection. By integrating rubber into the material, components can withstand substantially higher impact energies. In fact, initial tests indicated an increase by a factor of five before any damage became visible. The best results could therefore be achieved by combining hard (FRP) and soft (rubber) materials in alternating layers, which allows transfer of the energy from a thin FRP outer layer, which is still moderately flexible, to an elastomer layer. This soft layer distributes and absorbs the energy to such an extent that the underlying structure can be damaged only if subjected to considerably higher energy levels. "Although the design does require additional layers, they're very lightweight – the rubber is around 1.0kg/litre, while the FRP is just 1.5kg/litre or more," Plenk says. "It's an interesting alternative to a conventional structure as both the visual appearance and coatability remain the same."

Plenk says that the integration of Kraibon solves another familiar problem – splintering. "In the event of a collision or similar impact, CFRP components tend to break and splinter into many tiny pieces," he says. "The elastomer layer in Kraibon, however, is elastic and its strong bonding helps to hold the component together and minimise fragmentation." And to comply with the all-important stringent fire protection requirements of EN 45545, Gummiwerk Kraiburg has had Kraibon tested by a certified test institute.

This new composite material is also advantageous in that it can be integrated directly in the production process without the need for extra tools, processes or bonding agents, while it is also suitable for a range of processes (vacuum, autoclave, infusion, press), materials (CFRP, GFRP, SMC, etc) and temperatures (100-200°C). ☒



## CONTACT

florian.plenk@kraiburg.de; www.kraibon.com



Rubber improves composites



# KRAIBON®

## Featherlight acoustic damping for composites



Visit us at the Railway & MASS TRANSIT interiors:

12, 13, 14 November 2013

Koeln, Germany, hall 9, booth 5180!

[kraibon.com](http://kraibon.com)



# Festival of light

The latest solid-state LEDs are giving operators cause to celebrate, explains Transit Design Group

Until around a decade ago, rail lighting technology hadn't really progressed all that much from the incandescent lights that were first installed in passenger trains in the early 1900s. But the global phase-out of incandescent lighting implemented in around 2005 has left an illumination void for which competing systems such as compact fluorescent lamps (CFLs) and light-emitting diodes (LEDs) have emerged as the leading contenders battling for supremacy, says Transit Design Group (TDG). "No matter how close the battle lines are drawn, though, I think a case can easily be made for LED being the best of the two technologies," says Marc Gagne, associate vice president of business development for rail projects at TDG. "Now is the perfect time for its implementation."

## LED by example

Using CFLs to illuminate new or to retrofit existing vehicles simply isn't practical in Gagne's view and would add cost and complexity because of factors such as wiring. He says this leaves operators with a choice between the traditional linear fluorescent tube lamps or newer LED systems.

"LEDs yield benefits that are perfectly suited to help a challenged rail industry," Gagne feels. "And that's really important for a sector

**MAIN:**  
Demonstrating  
the difference  
between LED  
(top) and  
fluorescent  
(bottom)  
lighting  
solutions

that is being inundated with demands to reduce overall costs, power consumption and emissions, while at the same time increasing efficiency, safety and services."

Operating life in particular is a vital factor. Gagne says most high-quality LED datasheets show expectancies of 50,000-100,000 hours, while typical linear fluorescent datasheets show a range of 10,000-24,000 hours. "And LED lifespan can be hugely extended by simply reducing the drive current powering the system," he adds.

Although recent studies show that the efficacy of LED luminaires is similar to that of fluorescent lamps, efficiency increases are expected for LEDs in the future, says Gagne. "Leading-edge LED luminaire manufacturers are able to provide those efficacy increases today by applying lower drive currents to high-efficiency LEDs," he continues. The table opposite shows how TDG's LED main lighting system performs in terms of power consumption, alongside typical fluorescent light systems.

Employing a lighting system that uses less power gives transit authorities a lot of opportunities – they can take advantage of the decreased load placed on existing main vehicle batteries (especially helpful as a back-up for emergencies), specify smaller batteries or use the watts saved to power additional features such as security cameras, GPS or wi-fi.



The chart shows the approximate range of efficacy for various common light sources, as of January 2013. The black boxes show the efficacy of bare conventional lamps or LED packages, which can vary based on construction, materials, wattage or other factors. The shaded regions show luminaire efficacy, which considers the entire system – including driver, thermal and optical losses. Of the light source technologies listed, only LED is expected to make substantial increases in efficacy in the near future.

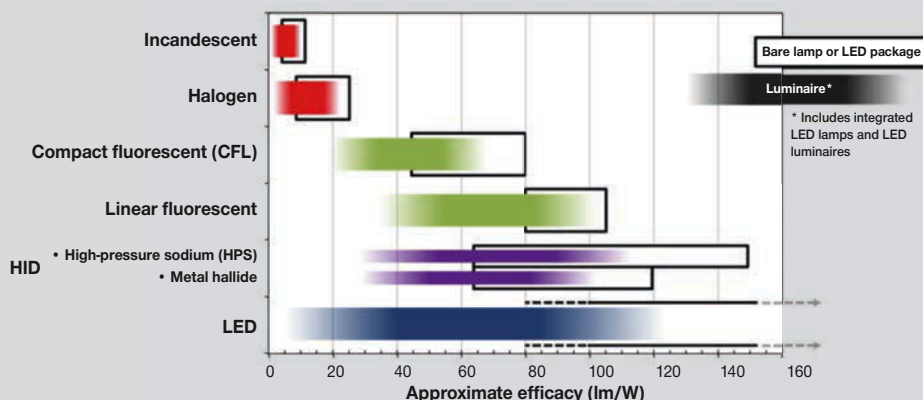

Well-designed lamps that use lower drive currents can also enjoy extended operational life, translating into fewer replacements for operators. “Each fluorescent lamp replacement can incur a cost ranging from US\$30 (£20) to US\$160 (£102) depending on how the transit authority calculates the event,” says Gagne. “As well as the inventory cost, maintenance labour and hazardous waste disposal may be factored in. A typical bi-level passenger car could have around 50-60 fluorescent fixtures, so again these replacement costs become significant when calculated across fleets.”

TDG also believes there are environmental benefits to employing LEDs. “All fluorescent lamps contain mercury, whereas LEDs don’t and as a result require no special, hazardous disposal,” says Gagne. Continuing on the environmental theme, fuel/energy costs should be factored in, too. Gagne calculates that a litre of fuel is required to generate 1kWh of power from a locomotive auxiliary generator. When extrapolated over fleets consisting of multiple cars and over longer periods such as a year, even small power efficiencies can have a big impact on the bottom line. “Furthermore, lower levels

**BELOW:**  
A railcar refurbished with LED-based lighting systems

of radiated heat from cooler LED main lighting systems would also reduce the load on vehicle air conditioning systems and fuel consumption as a consequence,” he says.

### Safety and comfort

Gagne notes that the rail industry’s flame, smoke and toxicity requirements make polycarbonate the lens diffuser material of choice – and here LEDs have another advantage. “Unlike fluorescent lamps, LEDs do not emit ultraviolet rays – which yellow polycarbonate diffusers in the same way that sunlight yellows or hazes car headlight covers,” he says. “Lenses that are dirty and yellowed with age can impair the light transmission by as much as 50%. Further improving passenger comfort, LEDs do not flicker, nor do they produce any audible hum such as that produced by fluorescent ballasts.”

Gagne also says LEDs offer greater durability than their fluorescent counterparts. “As LED luminaires are solid-state, they are ideally suited to the rugged and harsh rail environment, with its shocks and vibrations,” he explains. “Not only that, but handling fluorescent lamps during maintenance will certainly expose the fragility of glass – T8 and T12 lamps can be 8ft long, and T5 lamps have a 0.625in diameter. This is not to mention the increased potential for exposure to mercury should the lamp be broken.”

On top of all these factors, Gagne contends LEDs offer improved colour rendition and better performance at low temperatures, for example during start-up. “So while there is an argument that LED efficiency must increase to offset the added costs over comparable fluorescent systems, it’s one based on inferior LED luminaires,” he concludes. “Superior solutions are available today to help any authority realise these advantages.” ☒



### CONTACT

marcgagne@tdgdesign.com; www.tdgdesign.com

POWER CONSUMPTION*				
Fixture size	Single fluorescent fixture **	Single LED fixture **	Fluorescent bi-level car with 55 fixtures	LED bi-level car with 55 fixtures
T8	35W	22W	1,925W	1,210W
T12	43W	12W	2,365W	660W

\* Based on 48in fixtures with equivalent light output. \*\* Factors a 10% (best case) ballast efficiency loss for fluorescent system and a 20% (worst case) loss for the AC/DC converter efficiency for LED option



# Full pelt

As well as adding an exclusive ambience, Boxmark's leathers are designed to offer durability, weight and environmental benefits

**L**eather manufacturer Boxmark invests continuously to develop products that meet the market's needs, and also in researching innovative processing technologies in cooperation with scientific research institutions. Its Xlight and Xtreme brands are just two of its numerous product developments.

The main selling point of Xlight is its weight, which is approximately 600g/m<sup>2</sup> when laminated. "This weight is achieved through modifications to the formulation in the tannery, which nonetheless leave the chemical and physical properties of the leather unchanged," says Eduard Kettner, general executive manager at Boxmark. "In doing so, the thickness of the leather is preserved. There is no need to build up extra weight with additional materials. Xlight reduces the total weight of each train, resulting in fuel savings and consequently lower pollutant emissions – meaning cost savings and a contribution to sustainability."

Boxmark also designed Xlight to meet all international standards, and to be durable and easy to clean. This product is also available with Xtreme treatment, designed specifically for those seeking an extremely hard-wearing leather, and has been awarded the Certificate of Material Excellence from Material ConneXion.

"This material meets the highest quality standards and has certificates that prove excellent resistance to mould, bacteria, disinfectants, dirt, oil, alcohol and water – including chlorinated and salt water," says Kettner. "It is highly stretch and tear resistant, break resistant even at sub-zero temperatures, highly abrasion resistant and flame retardant. This special leather boasts all-round protection, from the surface through the entire width to the back of the material. Furthermore, this protection is durable."

In terms of certifications, Boxmark says its railway leathers meet all required flame-resistant standards, including the new European Standard EN 45545-2009, HL1, HL2 and HL3.





Xlight and Xtreme, along with other leathers offered by Boxmark, are suitable for use in railway carriages on commuter and mainline passenger systems. Boxmark's product portfolio includes upholstery leather and ready-made seat covers for trains and stations, leather for wall panels and built-in parts, and leather wrapping for components, wall panels and built-in parts. The company believes supplying everything from a single source – from the raw hide to the finished seat cover – means it can offer greater flexibility and cost savings.

Rail clients include OEMs Siemens and Alstom, and operators Deutsche Bahn of Germany (ICE); ÖBB of Austria; City Airport Train of Vienna, Austria; SBB of Switzerland; and NTV of Italy (Italo). Products provided to these customers include ready-made seat covers, leather wrapping for wall panels and leather in bulk. ☒

#### CONTACT

eduard.kettner@boxmark.com; www.boxmark.com

**MAIN:** Luxury for first-class passengers

**ABOVE LEFT:** The treated leather is highly water resistant

**ABOVE RIGHT:** Xlight's durability can be boosted with the Xtreme treatment

#### GREEN PRACTICES

Boxmark has a strong focus on environmentally friendly, energy-efficient production, and aims for standards even higher than the rail industry's stringent legal requirements.

The company is certified according to the ISO management system standards ISO 9001, ISO/TS 16949, ISO 14001 and ISO 50001, and in accordance with the European Commission's Regulation on Registration, Evaluation, Authorisation and Restriction of Chemicals.

# Artificial intelligence

The latest lighting technology from SBF has an extra dimension to enhance passenger well-being - and it's coming to railcars soon

**C**urrently being tested in two Deutsche Bahn long-distance ICE T railcars, a new technology developed by Leipzig's SBF Spezialleuchten could well become the next big thing in dynamic onboard lighting, in doing so taking passenger comfort to an entirely new level.

Following intense collaboration with a number of universities and research institutes, SBF's engineering team has devised a system that replicates the natural course of daylight synthetically. "It goes way beyond the functionality and advantages of tunable white light," suggests Andreas Heilmann, head of SBF's electronics and lighting technology development department. "We've known for a long time that we can do so much more with light than merely provide illumination. Technological innovations such as tunable white light are almost old hat today. What we're introducing takes that technology a massive step further!"

## The feel good factor

More and more organisations across multiple sectors are recognising the potential of lighting systems that replicate the changing nature of light during the day - for example transitioning from a warm white early in the morning through to a cold white in late morning and into the afternoon, then back to a warmer tone in the evening.

It's thought this kind of simulation can have a positive effect on productivity and comfort. "It's proven that a temporarily increased proportion of blue in light can lead to greater efficiencies in working and educational environments, for example by boosting concentration," says Heilmann. "Meanwhile the proportion of red is known to enhance well-being and relaxation. Whether the 'daylight' is cast from a natural or artificial source, you just feel better."

SBF tested numerous lighting variants with Deutsche Bahn to achieve the right effect. "In the end we opted for a combination that has never been implemented in the rail vehicle sector before," states Heilmann. This includes both tunable white lighting and coloured ambient lighting. "Our primary aim is always to design the lighting to be as comfortable as possible, while also being energy-efficient," says Heilmann.

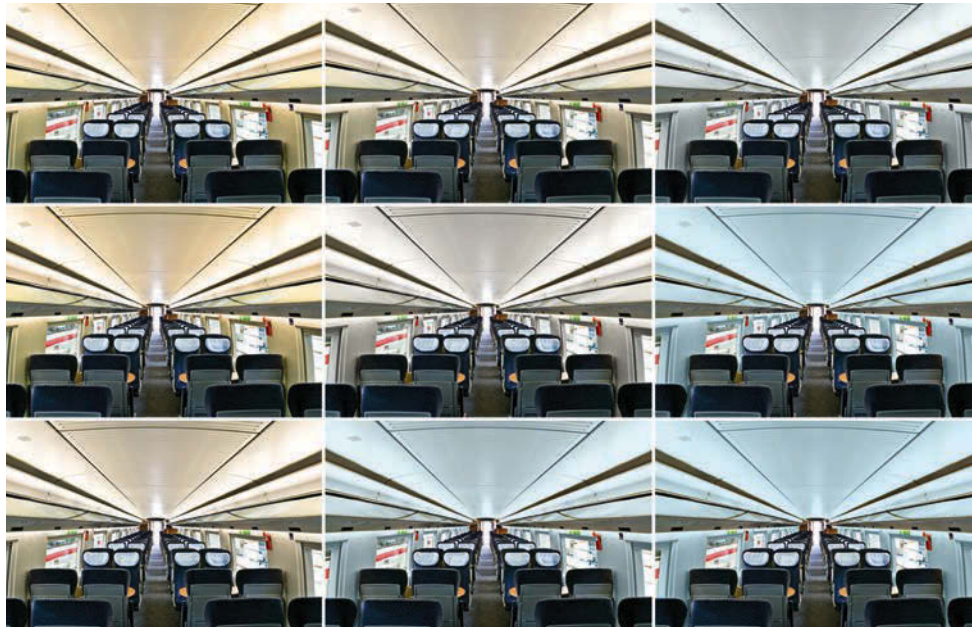

**ABOVE: SBF believes daylight simulation technology will take off in the rail sector**

To enable the conversion of the two ICE T railcars within a short timeframe, SBF developed a complete kit to replace fluorescent tubes and halogen spotlights with LED strips and brighter LED spotlights. Heilmann believes this to be the first time a railcar has featured tunable white light in accordance with DIN EN 13272. "All the artificial daylight and full-colour functionality (RGB) technology fitted accords with the necessary standards - even the dynamic lighting," he says. "We're really proud of the fact that with these test vehicles we have been able to try out virtually everything that is currently technically feasible."

So what's the hope for these groundbreaking ICE Ts? "The results of the tests could be used as the basis for subsequent ICE renovation and modernisation work, and will be incorporated into other SBF lighting developments," Heilmann confirms. "Our vision is that in the future, passengers in sleeper cars will be able to wake up nice and gently, or those on commuter trains can start their working day alert and attentive. Passengers will be able to concentrate when they need to, or snooze soundly at the end of a hard day at work. In short, they'll feel a lot more comfortable." ☺

## CONTACT

[info@sbf-germany.com](mailto:info@sbf-germany.com); [www.sbf-germany.com](http://www.sbf-germany.com)



# World Travel Catering & Onboard Services

**EXPO** | 8 – 10 April 2014  
Hamburg Messe, Germany

## The event

for travel catering, onboard retail  
and passenger comfort



### Interested in booking a stand?

For more information contact:

Mitra Esmizadeh

+44 (0)20 8910 7193

mitra.esmizadeh@reedexpo.co.uk

Register your interest in visiting at:  
[worldtravelcateringexpo.com/enquiries](http://worldtravelcateringexpo.com/enquiries)

The world's biggest passenger  
experience conference & exhibition

World Travel Catering  
& Onboard Services  
**EXPO** | 8 – 10 April 2014  
Hamburg Messe, Germany

Aircraft **EXPO**  
interiors

Passenger  
Experience **CONFERENCE**

Organised by:

Reed Exhibitions

# Holiday romance

KiwiRail needed a marriage of durability and style for the carpet on its new tourist trains

To enhance the experience for holidaymakers travelling through some of New Zealand's most spectacular landscapes, KiwiRail has added 16 'scenic' carriages to its fleet of tourist trains. Forbo Flooring Systems worked with Auckland-based design consultancy Barnacle Design to supply contemporary floor coverings for the new saloon carriages. Tessera Alignment, a richly textured cut and loop pile carpet, was specified to meet the operator's needs – which included style, comfort, durability and compliance.

The new carriages run on KiwiRail's Coastal Pacific, Northern Explorer and TranzAlpine routes, through snow-covered mountains and volcanoes, forests and deep ravines, and along the coast. Carpeted, centrally heated and air-conditioned, featuring panoramic side and roof windows, the carriages are designed to enable passengers to fully absorb themselves in the dramatic landscapes outside, while experiencing full comfort inside.

"For tourism-focused rail travel, the look and feel of the carriage interior is a very important factor in creating an environment with a convivial atmosphere in which passengers can really experience the scenery outside," says Keith Strode-Penny of Barnacle Design. "We needed a contemporary yet upmarket flooring solution that would work within our overall design scheme."

The designers and their client turned to Forbo Flooring Systems, having worked successfully with the manufacturer for many years. A luxurious product was required and so Tessera Alignment was specified from Forbo's extensive portfolio of sheet carpet. The company says this textured multi-height loop pile carpet works particularly well in enclosed spaces, with its bold directional theme tempered by intersecting random blocks of rich cut pile. Cyclone, a deep blue and charcoal colourway, was selected to work within an interior palette of natural blues, creams, greys and browns, drawn together to echo the colours of New Zealand's high country regions.



While the appearance was important, performance was critical. The soft flooring had to be extremely hard wearing – capable of withstanding the wear and tear and soiling associated with heavy foot traffic and the rigorous cleaning regimes required to retain appearance and maximise lifespan.

Because the trains feature open-deck observation carriages and stop at several places for passengers to disembark and experience the scenery, general rail dust is the predominant soil tracked through carriages. An additional issue on the TranzAlpine route across the Southern Alps is that the route is also used by coal trains, so coal dust gets tracked through carpeted areas in the carriages adjoining the observation carriages.

"A critical step in the transition between manufacture, commissioning and then entry into service, was setting up an

ABOVE:  
KiwiRail's  
new purpose-  
built scenic  
carriages



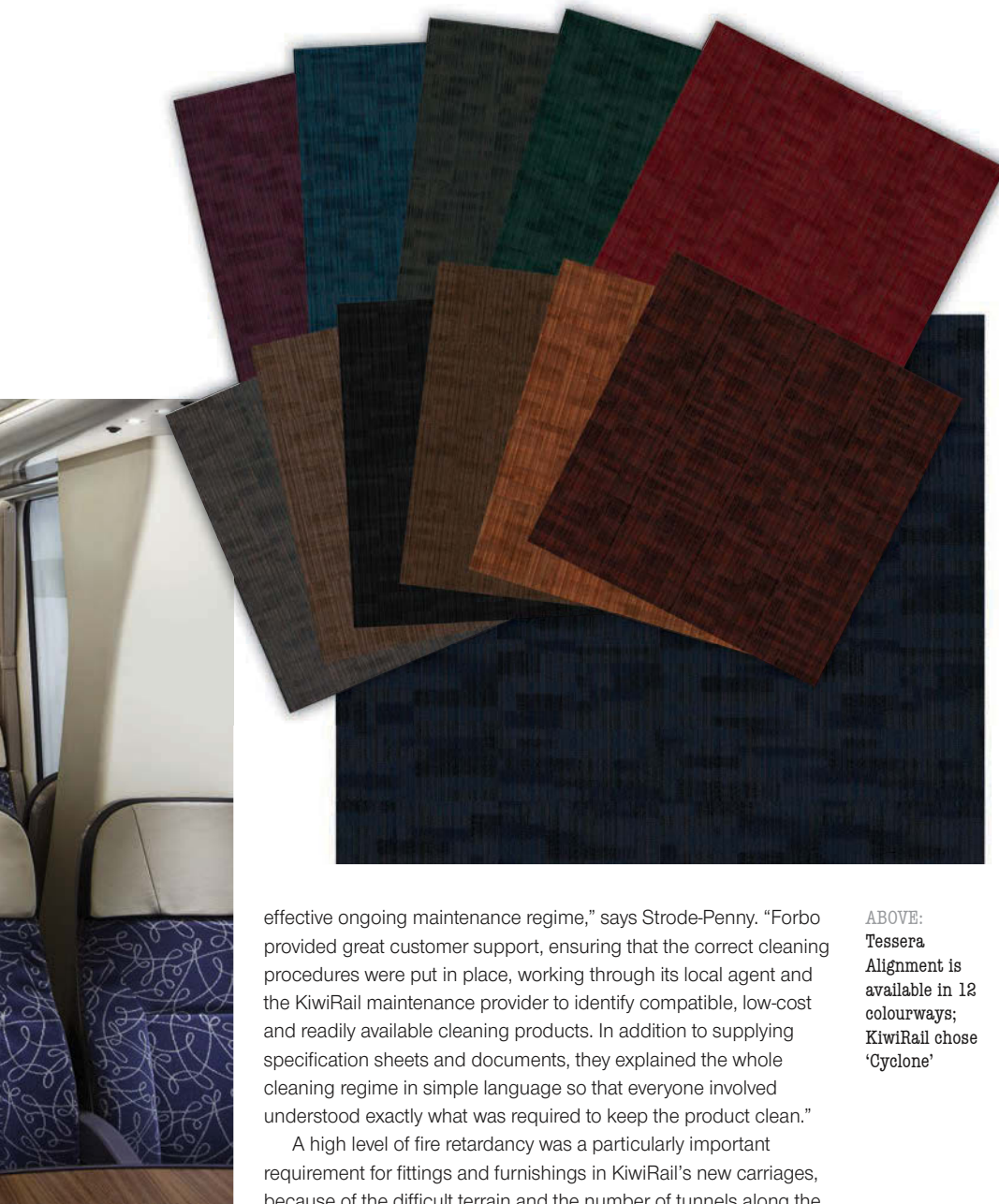

effective ongoing maintenance regime," says Strode-Penny. "Forbo provided great customer support, ensuring that the correct cleaning procedures were put in place, working through its local agent and the KiwiRail maintenance provider to identify compatible, low-cost and readily available cleaning products. In addition to supplying specification sheets and documents, they explained the whole cleaning regime in simple language so that everyone involved understood exactly what was required to keep the product clean."

A high level of fire retardancy was a particularly important requirement for fittings and furnishings in KiwiRail's new carriages, because of the difficult terrain and the number of tunnels along the routes. Forbo recommended Tessera Alignment 203 to meet all the required rail fire safety standards.

The floor coverings also had to comply with New Zealand's accessibility guidelines. For wheelchair accessibility, walking surfaces should have a coefficient of friction in all conditions of at least  $0.4 + 0.0125 S$  (where S is the slope of the surface as a percentage). Forbo says the product's densely tufted pile ensured this standard was easily met.

Tessera Alignment has now been in service on KiwiRail's tourist routes for nearly two years, and Forbo reports excellent feedback from both the operator and the design agency. "Once again we have had a positive experience of working with Forbo and its commercial floor coverings," says Strode-Penny. "When specifying global rail products for very small-scale New Zealand production runs, it can be a real challenge to try to persuade multinational suppliers to

go through the rigorous selection and tender processes, as they often have to invest just as much time and effort as they would for much larger projects closer to home. Forbo has always been a really enthusiastic and responsive supplier, from initial enquiry through to ongoing product support, and they provide excellent service."

Strode-Penny also says his consultancy will recommend this carpet again. "We will certainly specify Tessera Alignment again as it looks great, while being very practical," he says. "We know Forbo offers a bespoke design and manufacturing service, but we did not need to go down this route because of the attractive range of off-the-shelf colours available. Alignment also has the all-important fire ratings we need for passenger transport applications and it complies with disability access requirements. Where budgets are concerned, we have compared Forbo's product with standard heavy-duty contract-grade 100% wool carpet. It is undoubtedly more expensive, but lasts between two and three times as long in rail service, so it offers great value for money on an all-of-life cost basis."

These thoughts are endorsed by Richard Keenan, marketing manager at KiwiRail Scenic: "We're pleased with how Tessera Alignment performs. But this is what we expect from Forbo, given its excellent reputation. This carpet really works well with the other finishes and encapsulates our design brief – to bring the colours and textures of the high country inside the carriage. We are thrilled with the overall look and feel."

KiwiRail's panorama carriages were completed by the end of 2012 and introduced onto the premier TranzAlpine route. They are also being used on a new service named the Northern Explorer, which recently began operating through the volcanic regions of the central North Island, including the UNESCO listed World Heritage Tongariro National Park. With its stylish panorama carriages, KiwiRail has a platform to develop New Zealand rail tourism in new directions. ☒

**ABOVE:**  
Tessera  
Alignment is  
available in 12  
colourways;  
KiwiRail chose  
'Cyclone'

#### CONTACT

[info@forbo-transportflooring.com](mailto:info@forbo-transportflooring.com);  
[www.forbo-flooring.com/transportation](http://www.forbo-flooring.com/transportation)

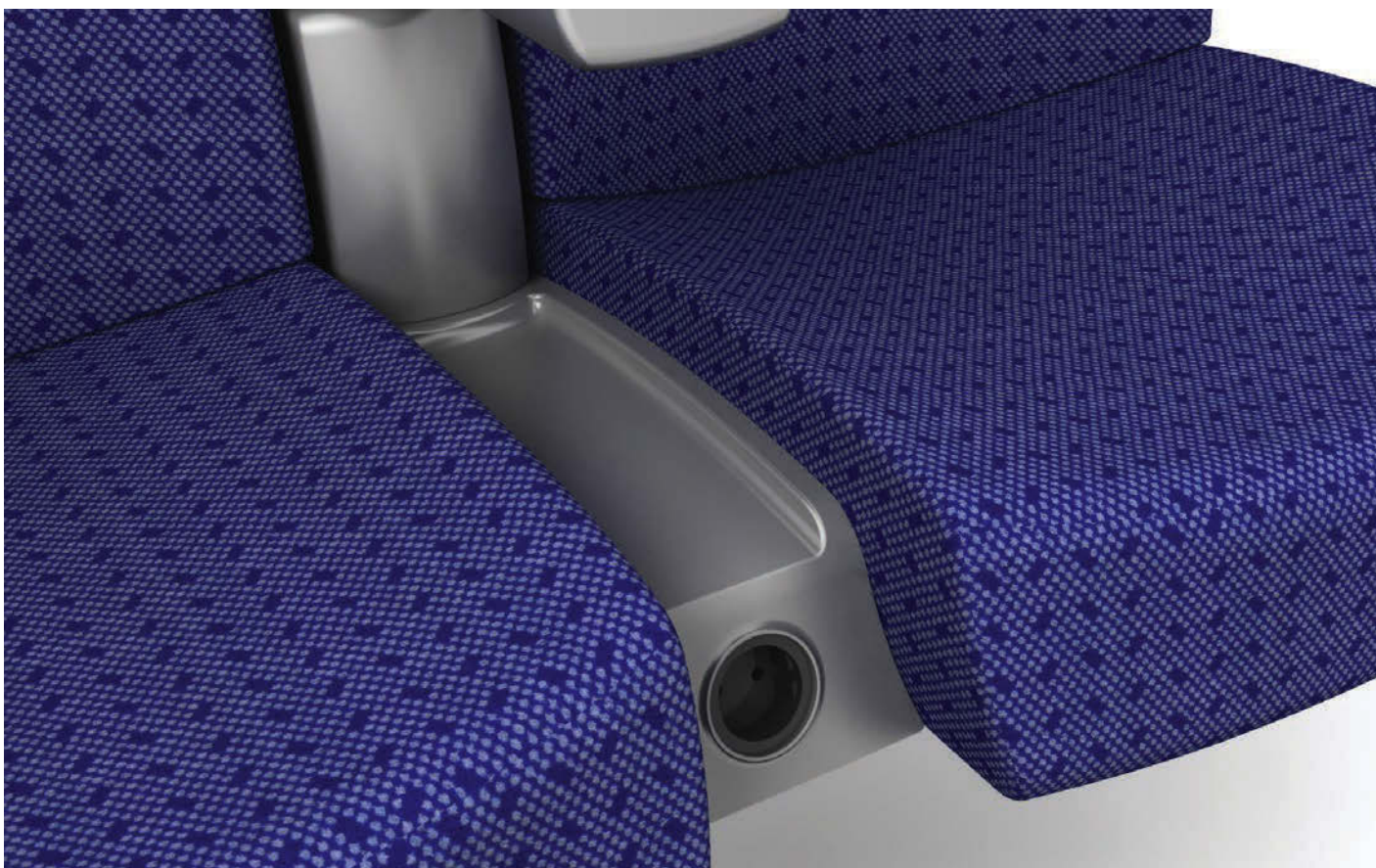

# Stretch out and relax

The Comfortline seat from Franz Kiel is designed to bring a new level of luxury to high-speed trains

**W**ith its new Comfortline seat, Franz Kiel, one of Europe's leading manufacturers of passenger seating for buses and railway vehicles, hopes to set a new standard for long-distance high-speed train travel. "High-speed trains are in a class of their own within rail transport," says Josef Vega, director of sales and marketing at Franz Kiel. "They glide across the country quickly and, for passengers, almost silently. Upmarket fittings and top-quality materials ensure a comfortable atmosphere. But in the future, with our new seat, passengers will be able to sit back and relax more than ever in these much-loved trains."

In development since early 2012, a prototype of the seat was shown to the industry in Berlin, Germany, for the first time in September 2012. The first application of the new seat will be in early 2014 for a customer in Scandinavia.

## Sitting comfortably

The new seat has been designed for maximum comfort. A newly developed cushion, for instance, is formulated to absorb almost all the train's motion, while a cushioned, ergonomically shaped

**MAIN:** The first-class model of Comfortline is available with numerous extra features, including power connection  
**RIGHT:** Armrests can be supplied to complement or contrast the main upholstery







LEFT: Motor-operated angle adjustment comes as standard  
 ABOVE: Flexible seating combinations are available

backrest is designed to provide optimum support. Passengers can adjust the tilt and height of the seat to suit their requirements.

The seat also features an optional fold-out footrest that can be set to a variety of positions, and an extra-wide head section with large headrest wings to provide a screened seating space into which passengers sitting behind cannot see. Armrests – included at the sides and in the middle of seat pairs – are foldable so that passengers can customise their surroundings according to what they find most comfortable. The armrest surfaces can be specified in colours that match the upholstery or provide a subtle contrast. An optional suspension system is also available to boost comfort further. Complementing the structure of the seat, Franz Kiel offers a range of top-grade upholstery options, in fabric or leather.

“All these little details add up to a step forward in comfort,” continues Vega. “Another advance is that Comfortline offers seat adjustment and recline as standard. Customers can also choose between a mechanical or electrical system.”

### Form fits function

Comfortline is also designed for multifunctionality. Similar to all Franz Kiel seating models, the construction is modular, so operators can build up their ideal product from the parts catalogue. Footrests, newspaper nets, coat hooks, cupholders, reading lights and a foldable table are all optional. The first-class model can even be equipped with a wide variety of communication options, such as a headphone socket for radio, a monitor in the seatback or a power connection for laptop computers. In addition the seat has a small shelf that can be used for items such as mobile



ABOVE: Shelving options ensure Comfortline is the ideal solution for onboard productivity

phones, complementing the main table, which is large enough for a notebook computer. “Comfortline provides a perfect mobile workstation for business travellers,” Vega confirms.

Various seating combinations are also possible – individual seats to provide quiet working conditions, double seats in rows with generous legroom and facing groups with a table in the centre for business meetings or for journeys with the whole family. “In addition, the seat’s compact construction also enables operators to add more seat rows or offer greater pitch,” Vega says.

Comfortline is also developed in line with the stringent EN 45545 fire safety standard, which comes into force in 2016. ☒

### CONTACT

info@kiel-sitze.de; www.kiel-sitze.de



# Form and function

Glass-reinforced phenolics can be moulded into complex shapes at a great price, weight and quality - all while meeting fire specifications, says Mtag Composites

**S**ince 2008, Mtag Composites has made many additions to its range of glass-reinforced phenolic (GRPh) products for the rail and aerospace sectors. Its senior team has more than 240 combined years of experience and has used its skills to develop advanced manufacturing techniques.

"The main advantage of the GRPh moulding process is that it gives rail interior design engineers more freedom to design complex shapes, which can be achieved with special composite moulding tools," says Nick Maltby, managing director of Mtag.

Mtag has developed its own closed-mould water-heater vacuum infusion process (VIP) to create composite mould tools, which Maltby says are relatively low in cost compared with steel tools. "This allows more mould tools to be manufactured for the same budget, increases production output and spreads tool risk," he adds. "VIP tools reduce the cycle time to a minimum, and retain lamination integrity and strength with maximum output. These moulds also allow material thickness to be controlled at any point on the panel, so weight can be minimised without reducing strength."

Mtag uses its VIP tools wherever possible - saying a further advantage is that exposure to the phenolic resin is minimised, enabling it to meet the industry's health and safety guidelines. "They also create a very smooth finish on both surfaces, which results in an excellent paint finish and a good substrate for the bonding of metalwork and fixtures," says Maltby.

In terms of certification, Mtag reports that GRPh meets the requirements of Class 1a for fire, BS6853 for toxicity and smoke,

BS476 for fire propagation and surface spread of flame, and London Underground Section 12. "We also use a number of paint systems, water- and solvent-based, that meet these BS fire standards, in any colour or gloss level," says Maltby. "We're currently developing self-coloured phenolic resins, which will display colour throughout the panel, prior to painting."

Another recent development was a carbon fibre phenolic composite seat for the commercial airline industry. The aim with this project was to take weight out while retaining strength and rigidity. The final product boasted a reduction in seatback weight of about 30%. "Combining carbon fibre with glass fibre makes costs competitive," says Maltby. "We see an opportunity for these types of panels in rail interiors."

Rail industry customers include Alstom, which contracted Mtag to deliver all the GRPh interiors for the Virgin West Coast mainline extension in the UK. The company also delivers interior and driver cab parts to Bombardier, supplies internal and external parts to a number of refurbishment and maintenance companies and is involved in a project for Crossrail, developing phenolic cladding panels for London Underground stations. Mtag also supplies glass-reinforced polyester mouldings for the bus, coach, leisure and boat sectors, and offers fire-retardant solutions for these products. The company holds ISO 9001-certification. ☒

**CLOCKWISE FROM MAIN:** Mtag GRPh window and ceiling panels in Virgin's West Coast mainline cabin; a customised composite mould; the West Coast mainline links London and Scotland  
**BELOW:** Nick Maltby, managing director of Mtag

## CONTACT

[nick@mtagcomposites.com](mailto:nick@mtagcomposites.com); [www.mtagcomposites.co.uk](http://www.mtagcomposites.co.uk)





# M TAG

composites<sup>LTD</sup>



**Mtag Composites Ltd**

Unit 4A Cowbridge Business Park  
Boston  
Lincolnshire  
PE22 7DJ  
United Kingdom

t: +44 (0)1205 352 992  
[www.mtagcomposites.co.uk](http://www.mtagcomposites.co.uk)

**EXCELLENCE IN MOULDING**

# Adjust in time

Five reasons to consider converting from fibreglass to thermoformed polycarbonate plastic, such as that used by Productive Plastics

**N**al Gilham, CEO of heavy-gauge custom plastic thermoforming company Productive Plastics, believes many operators could benefit by converting from fibreglass reinforced plastic (FRP) to thermoformed blended polycarbonate plastic for their mass-transit interior parts. "Certainly plastic thermoforming and fibreglass moulding can both be used to make parts for the mass-transit interior industry," he says. "However, blended polycarbonate and the thermoforming process used to manufacture parts from this material have some distinct advantages over fibreglass that motivate railcar manufacturers to convert."

The first advantage cited by Gilham is weight. "Depending on the type of material and a few other factors, the average thermoformed part is 30% lighter than its fibreglass equivalent," he says. "Reducing

weight saves fuel and energy, and decreases carbon footprint and operating costs. This has been accepted by the aviation industry and is slowly being adopted by the rest of the transport industry. According to a 2010 study by the US National Highway Traffic Safety Administration, a reduction of 360kg in an average bus can equate to a 2-3% saving in fuel. Additional benefits are a tangible increase in the life of vehicle components, such as brakes and propulsion systems."

The second point relates to manufacturing cost and time. "The process of manufacturing an FRP part is complex and labour intensive," says Gilham. "Multiple tools are often needed to complete a single part – increasing tooling, labour costs and production time. On the other hand, the thermoforming process is highly automated, relatively simple and typically requires less labour. Most applications require only a single tool per part. In smaller production volumes of 250-3,000 parts annually, thermoforming is often faster and cheaper than using fibreglass."

Third, Gilham believes thermoformed plastic gives designers more freedom – enabling the creation of extremely detailed and complex parts. "Diverse surface texturing options, precise

**BELOW:**  
Thermoformed plastics can be used to cut weight from railcars







ABOVE:  
A simple,  
automated  
production  
process  
reduces  
labour costs

tolerances for mated parts and complex geometry are just a few of the possibilities that are otherwise difficult or costly to fabricate with fibreglass," he says. "The availability of coloured plastic can also eliminate the need to paint the part. These advantages give designers the freedom to create complex modern designs that are more aesthetically pleasing and functional."

The fourth factor is environmental performance and industry compliance. "Thermoplastic raw material providers, such as Bayer MaterialScience and Kydex, have a variety of blended polycarbonate and other thermoplastic materials options that are not only compliant with US and European industry standards, but are also recyclable and VOC free – properties not shared by most transit industry fibreglass," contends Gilham.

Productive Plastics' fifth and final argument for thermoformed polycarbonate plastic is its durability. "On average, thermoplastic polycarbonate blends are four times more impact resistant than traditional fibreglass," says Gilham.

He adds that thermoformed plastic is flexible enough to deflect impact forces over its surface, allowing the material to recover from impacts that would crack a more rigid material. "This prolongs the life of the part, saving on maintenance," says Gilham. "Most transit-grade thermoplastic is also highly resistant to stains, chemical cleaners and graffiti."

### Talking points

Despite the benefits advocated, Gilham advises those planning to convert to thermoformed polycarbonate plastic that there are several points to consider first. "Custom thermoforming plastic part manufacturers are plentiful and often specialise in specific techniques, so it is important to choose a company that has the relevant expertise and experience," he says. "For vehicle interior parts, it is essential to look for companies that have extensive mass-transit experience, top-notch quality control and in-house design – and reverse engineering capabilities if you are converting from an existing part."

Obviously Productive Plastics presents itself as fitting this bill and also draws attention to its lean manufacturing techniques and

ABOVE:  
Thermoformed  
plastics can  
be made with  
different  
textures and  
tolerances

secondary assembly operations – which it says enables cost-effectiveness and short lead times.

Another consideration is the huge choice of raw materials available. "The polycarbonate thermoplastic used for mass-transit applications is typically blended with a number of other materials and additives to achieve the properties required by the mass-transit industry," says Gilham. "This has resulted in a wide selection of raw materials, each with specific tensile strengths, flammability, chemical resistance and weight, and engineered to meet a wide array of industry standards. A thermoforming manufacturer experienced in mass-transit applications can be an invaluable partner in choosing the right material."

With many material options and manufacturing processes available, each with its own pros and cons, there is no shortage of choice for the transportation interior industry. "While thermoformed polycarbonate may not be right for every application, it quite clearly provides solutions for the mass-transit interior market that other materials and manufacturing processes are hard pressed to match," concludes Gilham. ☒

### CONTACT

respond@productiveplastics.com;  
www.productiveplastics.com



# Good for vibrations

Floating floors boost comfort and lower costs, says Getzner Werkstoffe

**P**assengers, rail operators and rolling stock manufacturers can all benefit from a floating floor, contends Thomas Gamsjäger, product manager at Getzner Werkstoffe.

Specialising in the isolation and mitigation of vibrations, the company provides polyurethane components such as mats and strips for floating floor installations.

As a result of the heightened requirement for comfort, the company has seen particular demand for trains running on long-distance and high-speed networks. "On these routes the railways compete directly with air travel," Gamsjäger says. "Travellers tend to opt for rail if, in addition to fast travel times and punctuality, an appropriately high level of comfort is provided."

## What lies beneath

Getzner Werkstoffe says its floating floors contribute to comfort by reducing vibrations and the level of secondary airborne noise inside the railcar. "Customers who feel comfortable will travel by rail again and are usually happy to pay an appropriate price for a pleasant and relaxing journey," Gamsjäger adds. "This positive impact

**MAIN:** Floating floors are installed to reduce vibrations and therefore noise in the carriage  
**RIGHT:** Getzner's solution involves placing strips of polyurethane under the floor

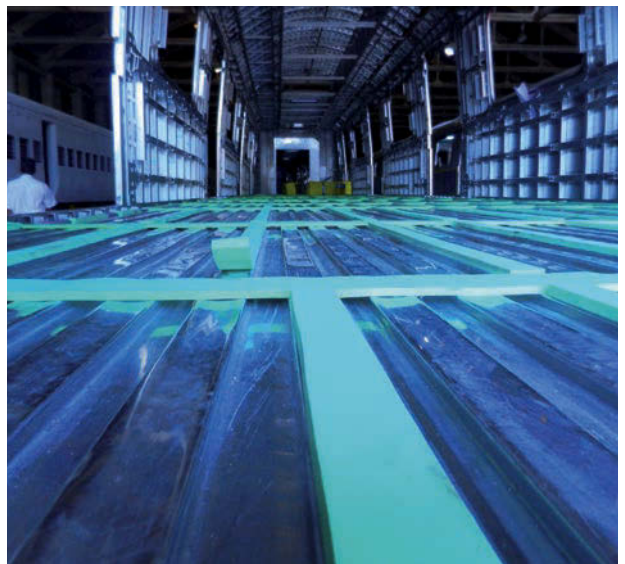



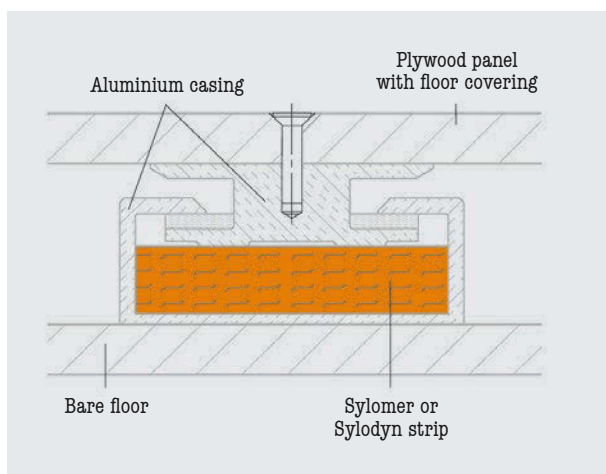

ABOVE: Example of a Getzner floating floor solution  
 RIGHT: Sylodyn, one of the polyurethane materials that can be used

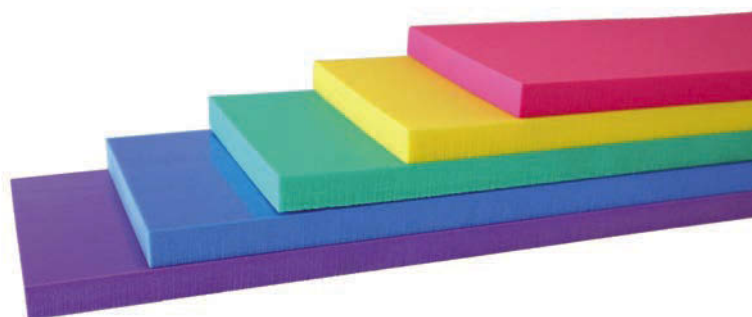

### HOW LOW CAN YOU GO?

Getzner's floating floor solution entails placing strips of polyurethane directly underneath the floor panels, which Thomas Gamsjäger says permits a lower floor construction, enabling the height of the railcar to be reduced.

"The Getzner solution has a beneficial impact on the overall weight and the aerodynamic properties of the train, leading to reduced energy consumption, fewer CO<sub>2</sub> emissions and lower energy costs," Gamsjäger adds. "The polyurethane bearings also give better results in terms of vibrations and noise compared with complicated sandwich constructions."

on passenger numbers and ticket price means a fast return on investment for the operator."

Achieving fewer vibrations inside the railcar also has the potential to protect interior fittings and consequently extend the service life of the stock. "Joints, electronic components and sanitary facilities all benefit," Gamsjäger notes. "Isolating vibrations means lower lifetime costs as maintenance is not required so often. This is a key sales argument for train builders."

Some rolling stock manufacturers assume elastic materials display inferior and continuous settling behaviour, but with Getzner materials, Gamsjäger says the opposite is true. "They exhibit much lower levels of settling than materials such as rubber," he stresses. Most settling, he adds, occurs in the installation of the floor panels and interior fittings, and with elastic bearings this "insignificant" deflection can be calculated in advance. The design can then be optimised to suit the train and country in which it will be used.

"Reduced settling means the elastic joints between the wall and the floor are subject to less wear, resulting in fewer stress cracks," continues Gamsjäger. "No weather- or cleaning-related liquids can

penetrate the floor construction – additional factors that extend maintenance intervals and reduce maintenance costs."

Getzner says using polyurethane for floating floors also yields advantages during installation. "The material can compensate for unevenness in the body shell and even it out over the length and breadth of the railcar," Gamsjäger says. "This eliminates the need for labour- and cost-intensive compensation elements, but the material's properties and advantages are unaffected."

### Safer by design

The company has also taken account of the stringent fire protection requirements for rail rolling stock in its development of Sylomer FR. "This material meets the highest possible hazard level, HL3, and therefore complies with CEN/TS 45545-2 (R9 – Floor Constructions), the new European standard for rolling stock," says Gamsjäger. "The fire protection requirements set out in the US NFPA 130 and the Japanese JRMA are also satisfied."

Ultimately, elastic materials from Getzner have been used in rail superstructures for more than 40 years – experience that enables the company to predict material properties over the service life of a train, and promise consistently high quality. Gamsjäger illustrates this by referring to a series of tests carried out by an independent institute in 2012, on some Getzner materials that had been installed under a stretch of track near Stuttgart 28 years ago. "After almost three decades of constant traffic, the specification of the material hadn't changed at all," he concludes. ☒

### CONTACT

thomas.gamsjaeger@getzner.com; www.getzner.com

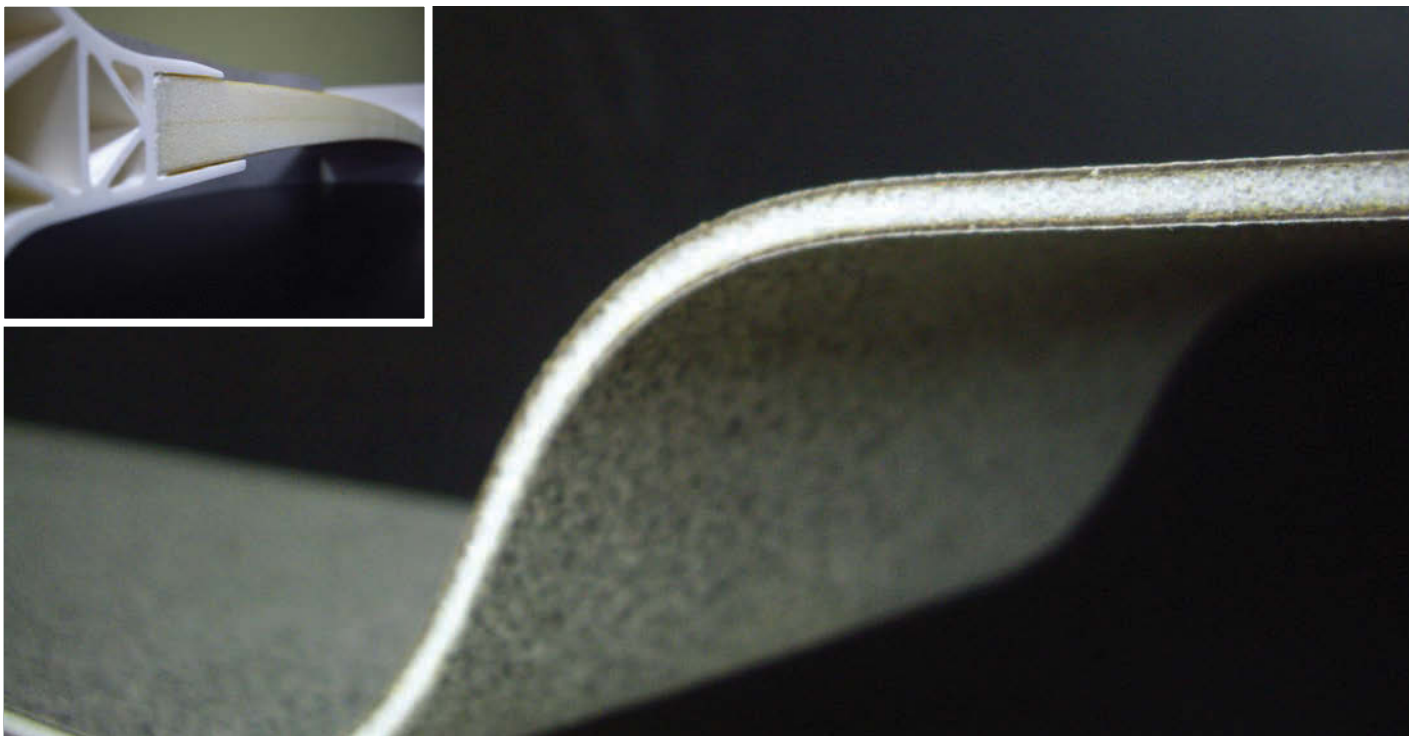

# Strong footing

Weight, strength and safety are the key areas of focus in KorbaDesign's latest development - a composite floor

**B**ased in Barcelona, Spain, KorbaDesign offers comprehensive design services for bus and rail OEMs. One project the company is working at the moment is a composite floor that it believes will benefit not just the OEM and the end user, but through its environmental benefits, the wider community as well.

"The starting point for the development was to minimise weight, to enable the train to run faster and more efficiently, while reducing emissions," reveals Alfons Garcia, who heads up the CAD design team at KorbaDesign.

The company believes faster running times and greater efficiency are becoming more important to passengers because the proliferation of smartphones and social media means they are used to having everything at their fingertips instantly. These technologies also provide passengers with a very public platform to provide instant feedback regarding an operator's service. Safety and environmental impact are particularly prone to public scrutiny.

"The second but equally critical aim of the development was to maximise impact absorption and strength," continues Garcia. "The design brief was to create a floor that wouldn't require the existing steel support structure. It had to be self-supporting, able to carry a large number of people and capable of withstanding the forces of an impact in an emergency. Stopping the spread of fire, reducing smoke levels, absorbing impacts and maintaining a protecting structure are extremely critical factors in the event of an emergency."

To achieve these important criteria, the team selected a hybrid composite that incorporates Kevlar and other fibres, combined with a special epoxy matrix. "This provided the needed structural performance, impact absorption, fire resistance and environmental durability," confirms Garcia.

The management team at KorbaDesign has been working in the composites field for many years. Initially specialising in the bus and rail markets, the company is now developing products for the aerospace and other (non-transport) markets, and believes these industries can educate each other.

"You can always learn something from everyone, so it's critical to network and study how other sectors work," says Raquel Gomez, who leads the quality control department at KorbaDesign. "For the composite floor project we studied developments in composite aircraft and also the ballistic protection industry," Gomez reveals. "We combined this technology with the assembly line approach used by the automotive industry in order to achieve a cutting-edge product that is affordable."

KorbaDesign is currently working on a number of projects around the world. "Change is the name of the game," Gomez concludes. "If you want to stay ahead, you must be prepared to change every day and avoid shortcuts." ❌

**MAIN AND INSET:** Kor Panel is a lightweight panel system for mass-transit applications that boasts thicknesses as low as 3.5mm

## CONTACT

dale.buckley@korbadesign.com; www.korbadesign.com



# Korbadesign S.L.



Development, Design  
and manufacture of mass  
transit interiors

- Lightweight structural floor and roof structures
- Fire retardant partitioning and panelling
- Airconditioning ducting
- Acoustic panelling systems

**The environmental solution**

LRQA ISO9001:2008 certified production





# Group effort

Pooling expertise in surfaces and soft furnishings is proving efficient for the Scottish consortium Rail Interiors Solutions and its customers

**T**he global rail interiors market is benefiting from the skills and experience at the heart of Rail Interiors Solutions. The Scottish consortium of suppliers is focused on assisting customers such as Bombardier, First Great Western, Eurostar and Alstom to create top-quality, modern and comfortable carriages.

The group comprises five firms – Andrew Muirhead & Son, Forbo Flooring, Novograp, Replin Fabrics and Transcal – each bringing its own area of expertise to the table. Each completed project pushes the reputation of Scotland's textiles industries higher and further – demonstrating that both new-build and refurbishment operations can be taken on and fulfilled from Scotland.

One project illustrating the group's collective strengths involved the interior refurbishment of 27 Meridian 222 trains for UK operator East Midlands Trains. Standard-class seating fabrics were supplied by Replin Fabrics, while leather for first-class seats was provided by Andrew Muirhead & Son. Working at East Midlands Trains' depot in

Derby, UK, seating specialist Transcal completed its contribution in no more than eight working days per train – well inside the challenging deadline all parties had agreed on. With seating areas transformed, focus switched to interior surfaces, the specialism of Novograp. The firm provided a solution that can be used for walls, tabletops and bulkheads, and is designed for durability, ease of installation and fire safety. Meanwhile, hardwearing vestibule matting and linoleums were supplied by Forbo Flooring.

All the solutions used aim to help the carriages withstand their heavy use so they stay fresh – benefiting the operator by reducing maintenance and enhancing the passenger experience. For example, Replin's fabrics include a patented anti-staining treatment, while Novograp's surface solutions are formulated to resist graffiti. The £6m project was completed in February 2012.

"Working together as a group is driving efficiency," says Steve Harvey, sales director at Transcal. "We meet regularly and have face-





## ◇ CARBON FOOTPRINT

High on the group's agenda is a dedication to minimise its carbon footprint. During installation it bases staff at the customer's site whenever possible, reducing the number of journeys taken and therefore their impact on the environment. As well as reduced costs, another spin-off is that less time spent travelling between sites means more time spent on them.

Andrew Muirhead & Son, which is part of the Scottish Leather Group, has taken its environmental commitment a step further by designing and building its own thermal energy plant. The plant converts the company's waste into energy used to operate its tannery.



to-face discussions about projects we're involved in, and new business we want to target. There's strength in numbers. As a group we have more than 300 years of experience in supplying quality solutions to the transport industry, as well as a combined turnover that goes a long way to satisfying the procurement managers and bid teams we work with."

Rail Interiors Solutions also says the collective nature of the group enables it to offer reduced costs, smoother project management, greater flexibility and a single point of contact.

### Expo plans

The consortium is now busy seeking new contacts, customers and projects. Collective experience lifts the group into an arena where international business is a realistic prospect. Central to this ambition is attendance at Railway and Mass Transit Interiors Technology and Design Expo 2013, held in Cologne, Germany, on 12-14 November.

**MAIN:** One of the trains refurbished for East Midlands Trains

**ABOVE LEFT:** All the work was completed at the client's site in Derby

**ABOVE RIGHT:** All textiles and surfaces were replaced

The event provides an opportunity for the group to target global specifiers, designers and buyers working on new-build and refurbishment projects. It's a long-established showcase for the train interiors sector, and it's exactly where Rail Interiors Solutions needs to be to continue demonstrating Scottish innovation.

"Major opportunities – both in the UK and internationally – are presenting themselves," says Archie Browning, sales director at Andrew Muirhead & Son. "That's why we're attending Railway and Mass Transit Interiors Technology and Design Expo for the second time. The event is crucial for all the specialists that make up Rail Interiors Solutions. We'll be there delivering the message that in Scotland we really do have a world-class one-stop solution for interior projects." ☒

### CONTACT

[enquiries@scotent.co.uk](mailto:enquiries@scotent.co.uk); [www.scottish-enterprise.com](http://www.scottish-enterprise.com)



# Northern star

VIA Rail Canada has chosen Julien Rail Solutions for the refurbishment of its HEP1 Chateau and Park cars

In 2009, VIA Rail Canada started a major programme of transformation, encompassing locomotives and passenger cars, to provide passengers with a more comfortable and enjoyable travel experience from start to finish. Much of its fleet is being upgraded, renovated, refurbished and rebuilt, including 12 of the iconic HEP1 train cars that trek across the country.

Key parts of the programme include enhancing accessibility for persons of reduced mobility (PRM) in line with ADA requirements; improving the cars' operational reliability and lifespan; redesigning interiors to improve aesthetics and comfort; adding new business-class single seating options; and on the

**MAIN:**  
The HEP1 bedrooms feature spacious seating areas upholstered in leather

HEP1 'Canadian' service, adding new options for passengers in Sleeper Touring class.

In August 2012, Julien Rail Solutions (JRS) from Quebec City, Canada, accepted the challenge to deliver a complete solution for the HEP1 facelift. The mandate encompasses the integration of design and engineering of all components in each car, plus fabrication and installation of these components at its facility in Charny, Quebec. The first HEP1 cars are scheduled to be ready by the end of 2013.

The work started with a complete inspection of each car using 3D laser scanning technology to obtain exact data for a 3D model. A visual inspection was also necessary to diagnose and repair electrical, plumbing and HVAC systems, plus the car body structure.

Detailed design and integration of all components and systems was performed and a mock-up was produced to validate design, ergonomics and layout. JRS worked with VIA Rail's design team







RIGHT: An en suite bedroom with flatscreen TV



## THE HEP1 PROJECT

The HEP1 cars are used on VIA Rail's Canadian service, which links Toronto and Vancouver. With the refurbishment, VIA Rail's intention is to provide a luxurious hotel-type environment, with deluxe services and amenities similar to those on cruise ships.

Each Chateau car will have six standard bedrooms, while each Park car will have one standard bedroom, one fully accessible bedroom, a lounge and a bar area.

Highlights of the lounge and bar area include a newly designed seating area and special materials and finishes such as upscale leather, quartz countertops and stainless steel. Heating is provided in all sections of the cars, with radiant heating in the floor and the outboard walls.



to ensure that all the materials used for the components met their requirements, especially for fire, smoke and toxicity.

Special attention was paid to the requirements of PRM passengers. Each Park car has an ADA-compliant accessible deluxe bedroom with wheelchair access, plus adapted accessories and controls throughout the bedroom, washroom and shower.

### Testing times

Every component created for the project was submitted to computer-generated finite element analysis (FEA) to ensure accuracy. Testing of materials included temperature cycling tests, adhesion tests, insulation tests and colour matching. FEA mechanical cycling tests were performed on all major components to simulate 10 years of use. Physical tests were also performed to demonstrate resistance and ruggedness.

A series of prototypes was built and installed on the cars to validate the final design. Components are made out of materials such as fibre-reinforced plastic, plymetal, honeycomb, stainless steel, aluminium, mild steel, high-pressure laminate, other laminates, carpets, upholstered equipment, leather and fabrics. The prototype of the accessible deluxe bedroom and bathroom includes a sofa, beds, coffee table, shower and a very low-noise miniature solid-state refrigeration unit (a minibar). Audio and visual equipment was also integrated throughout the Park cars.

JRS's mandate also includes procurement and vendor relations. The company is managing the design and approval of all parts through a range of partners in Canada and the USA. ☒



LEFT: Completely redesigned lounge area with widescreen TV

### CONTACT

[sales@juliens.com](mailto:sales@juliens.com); [www.julienrailsolutions.com](http://www.julienrailsolutions.com)

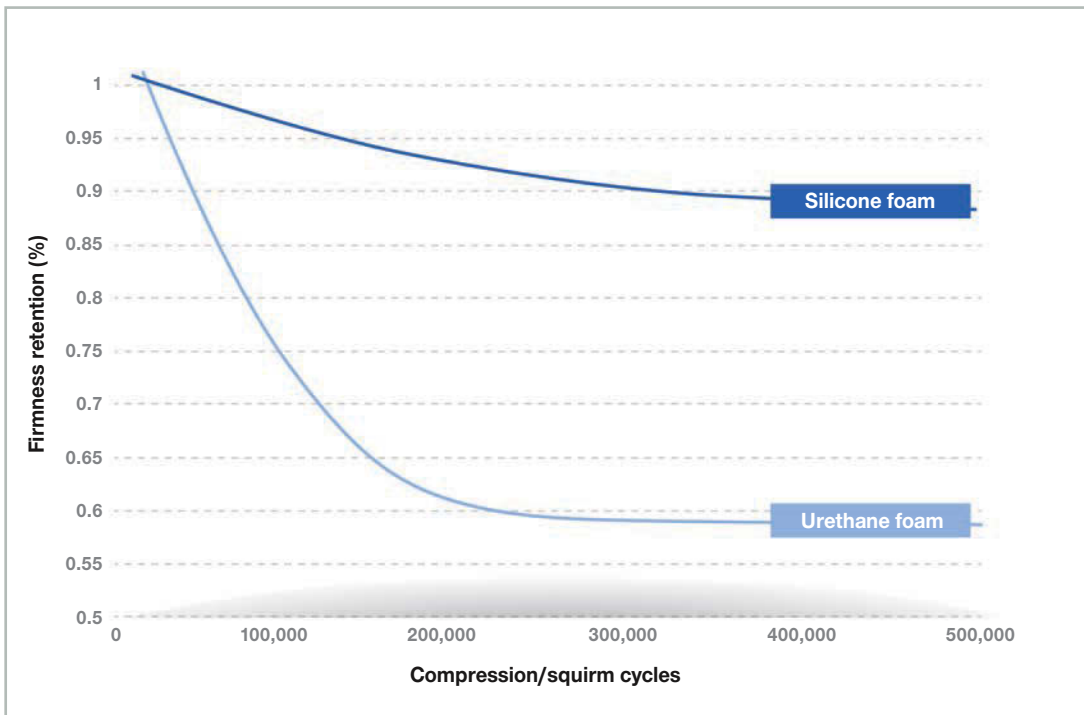

Long-term durability tests demonstrate the benefits of a silicone-based foam cushion against urethane foam equivalents

# All rounder

The silicone seat cushion foams offered by Rogers Corporation are designed to meet the demands of transit authorities, passengers and designers alike

As the focus on rail travel continues to increase around the world, concerns surrounding passenger safety and comfort do as well. Pair those concerns with the cost of building and maintaining not only the infrastructure but the trains themselves and the challenge grows. Rogers Corporation says its Bisco silicone materials make solving some of today's challenges much easier, while making tomorrow's challenges almost disappear.

"The Bisco MF1 seat cushion foam is lightweight, flame retardant, easy to fabricate and time tested," says a spokesperson for the company. "This silicone material is guaranteed for 10 years and is designed to meet global flame, smoke and toxicity (FST) standards without sacrificing durability or comfort. In fact, this material is already being used in many railway seating applications worldwide, in places including Baltimore, Chicago, New Jersey, New York and San Francisco in the USA; Toronto in Canada; Taiwan; and London in the UK."

For those requiring an even lighter though no less durable material, Rogers Corporation recently launched Silfx comfort foam, a top pad material that is designed to increase comfort and decrease weight. This non-petroleum-based silicone material was developed to enable thin cushion design, longer cushion life and lasting passenger comfort. "Simply put, Silfx silicone comfort foam is the lowest-density flame-retardant silicone in the world and can be easily incorporated into many seat designs," says the spokesperson.

Rogers Corporation believes that as durable cushion solutions for passenger railcars, Bisco MF1 and Silfx materials will help transit authorities, passengers and rail designers alike. "The benefits for transit authorities include the durability of these materials and the ability to create thinner seat designs and therefore decrease weight," continues the spokesperson. "With these materials being as durable as they are, refurbishments will be needed less frequently, reducing not only labour costs but downtime as well."

For passengers, the main demand is comfort. "With Bisco silicone materials, that's what they get," adds the spokesperson. "Comfort from seat to seat, car to car and year to year. Pair that with the FST performance of the material and passengers have nothing more to think about than where to sit."

Rogers Corporation believes its materials also tick every box for seat designers, who are faced with creating a seat that reduces space, keeps passengers comfortable and safe and keeps the train in good working order for as long as possible. "On a more personal note, they're challenged with designing a seat they can stand behind," the spokesperson notes. "Bisco MF1 and Silfx materials allow designers to have peace of mind knowing that what they design will last over time and perform as planned." ✕

## CONTACT

[solutions@rogerscorp.com](mailto:solutions@rogerscorp.com); [www.rogerscorp.com](http://www.rogerscorp.com)



# ONLINE SUBSCRIPTION AND READER ENQUIRY SERVICE

**SUBSCRIBE  
NOW!**



Request more details about  
the advertisers in this issue  
of Railway Interiors  
International online at:

[www.ukipme.com/railway](http://www.ukipme.com/railway)

# Home stretch

Rica Seats has dominated its domestic market for years - now it plans to bring comfort to the world

**R**ica Seats' story began roughly 25 years ago, in 1988, with the founding of Riihimäen Metallikaluste, a brand name later shortened to make it easier for international customers to pronounce. The company is based around 60km north of Helsinki, in Riihimäki.

"Our know-how in steel components and in product development is based on years of experience and a determination to find better and more effective solutions to meet the needs of clients, as well as constantly evolving marketplaces," says Timo Tanni, CEO of the company.

In the 1990s when Rica started seat production in earnest, most of its focus was on subcontracting furniture for auditoria and bus seats. Train seats appeared in its range a few years later, finding favour with VR, Finland's national railway, which used them for multiple projects. In fact, Rica has now supplied more than 90% of the seats used on Finnish trains.

The company has enjoyed other considerable successes too. More than 45,000 seats have been delivered and installed by Rica Seats since 1994. Consequently, through various client requests over the years, its product range has expanded to include such elements as play areas for children and tables, while more recently a whole restaurant car interior was created. Rica's seat design and manufacturing know-how was most recently recognised in 2012 when its Aicon model for auditoria won a Baden-Württemberg International Design Award.

Despite these successes, though, the company's ambitions stretch far beyond the borders of its home territory. With a restructuring of its ownership and new shareholders in 2011, a new export-oriented strategy was launched that has seen Rica Seats investing in new manufacturing premises and machinery. The aim is to become a household name in the rail market across the world.

"Our strength lies in our size and structure, which allows us to respond swiftly and flexibly, to take part in a client's product development where appropriate, and create products that can be cost-effectively adapted to suit a wide variety of applications," says Georgy Sveshnikov, project manager at the company. And through

**MAIN:** Finland's VR employs children's play areas as the centrepiece of its family-friendly travel concept



**LEFT:** Seats and tables from Rica feature in Atlantic Design's Mark IV concept  
**RIGHT:** The standard-class seat Rica developed for the Mark IV





## INVESTMENT PORTFOLIO

Folmer Management became the main shareholder of Rica in the autumn of 2011. More than €1.3m (£ 1.1m) has since been invested in two new assembly lines at the company.

The first line is capable of producing 20,000 seats a year for metros and trams. The second is for intercity-style seats, with a capacity of 13,000 seats a year.

The company employs approximately 30 people and contracts additional personnel when necessary. In 2012 Rica had a turnover of €6.6m (£5.6m).

working in close collaboration with UK-based Atlantic Design, Rica is now seeking to enhance this flexibility using what Sveshnikov describes as the best of Scandinavian expertise in aluminium fabrication and bonding techniques to develop a new range of rail vehicle seats based upon bonded honeycomb structures.

"Such a lightweight approach offers real environmental benefits through energy savings for train operators, not to mention the fact that approximately 60% of the raw material is recycled," he notes. "This low weight helps to ease installation and crucially the ultra-slim construction means that more space is provided for passengers."

Another key advantage is that the production system and the seat itself have been designed to minimise the need for tooling. "This means that it remains cost-effective to produce design variants in relatively low volumes," comments Sveshnikov. "Naturally the seats can be covered with fabric, leather or e-leather according to the client's requirements."

Tables can be made with the same lightweight honeycomb construction, again facilitating a wide range of design options including table-extension cartridges, cup holders, integrated LED lighting and perhaps even wireless charging for electronic devices.

### Quality controlled

In line with these new manufacturing technologies, Rica is also updating and developing its existing ISO 9001 quality management system. "I would suggest a good example of our product quality can be seen in the children's play area on the Allegro trains operating between Helsinki and St Petersburg, Russia," advises Tanni. "These have now been in service for five years without any faults or complaints."

Rica Seats is one of more than 100 exhibitors at this year's Railway & Mass Transit Interiors Technology/Design Expo in Cologne, Germany, which takes place on 12-14 November 2013. "With all these developments now well under way, we have a really positive vision for the future of our products that we're excited to discuss further," Tanni says. "We look forward to welcoming you to Stand 5005!" ☒

### CONTACT

jussi.pohjola@rica.fi; www.ricaseats.com

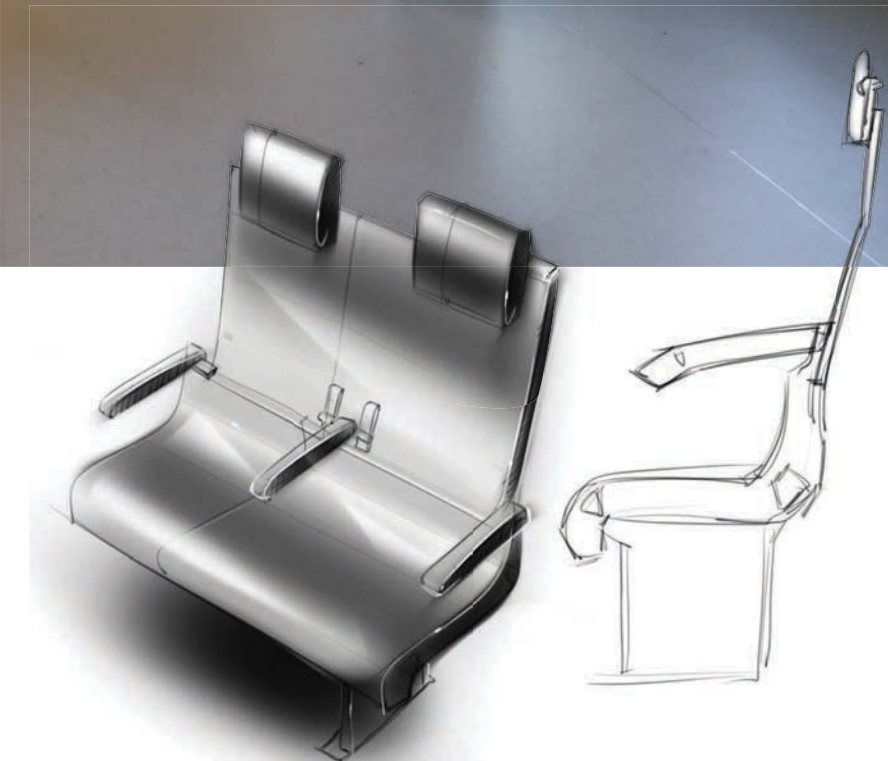

The Arriva Trains  
Wales contract included  
luggage racks



# Innovative interiors

Building sustainable, collaborative relationships with clients can only succeed, insists Bakerbellfield, with a focus on high-quality products and customer service

In 2006 Bakerbellfield (BB) secured its first major rail project when it was contracted by Bombardier Transportation to supply tables for UK operator First Great Western. BB boasts a solid basis in project management gleaned from multimillion-pound construction projects and has been manufacturing interior components for the rail industry since 1993. These skills were put to good use on the First Great Western project, and BB achieved an on-time delivery rate of more than 98%, with only a small number of minor change requests.

Since then, it has gained recognition as a rail interior specialist, working on multiple projects as an integral part of customers' design teams. BB's aim is to add value to projects not only by reviewing the materials that customers plan to use, but also by looking at ways to improve the efficiency of manufacturing and logistics processes, to make costs as competitive as possible.

"We take time to understand how our customers intend to deliver our products to the production line and how they propose to install them,

**BELOW:**  
Bakerbellfield's  
Universal  
Access Toilet  
module

paying particular attention to any interface issues that may need addressing," says Darran Hodgetts, managing director at BB. "We then provide suggestions on how to improve the design."

BB's commitment to the rail industry was confirmed when it achieved International Rail Industry Standard (IRIS) accreditation for interiors work (BB was the first interiors company in Europe to acquire IRIS). "This has provided us with a structured approach to project introduction, including FAIR recording and Product Pack release," Hodgetts adds.



## Crashworthy tables

In 2010, BB secured a contract to design and manufacture all the tables for Bombardier Transportation on the London Eastern Railway Stansted Express project. Bombardier provided the vehicle interface drawings and the design brief, requesting that BB control the design process.

BB quickly established a number of design principles that needed to be considered to ensure a successful product. Aesthetics, material costs, weight, fire performance, installation, servicing, static



## BB'S SCOPE OF SUPPLY INCLUDES

- Universal Access Toilet modules;
- Fixed, folding and sliding tables;
- Table legs;
- Luggage stacks and racks;
- PRM TSI grab poles and rails;
- Engineering components;
- Body panels;
- Body side fixing brackets/trims;
- Bulkheads;
- Call for aid;
- Ceiling panels;
- Cupholders;
- Cycle racks;
- Dado panels;
- Doors;
- Draft screens;
- Drivers' desks;
- Litter bins;
- Partitions;
- Composite panels;
- Solid-surface sinks and splashbacks;
- Storage areas;
- Flooring;
- Vanity units.



and dynamic loadings, injury criteria and the GM/RT 2100 Issue 4 crash test standards were all considered during the design process.

"The tables were tested at MIRA in July 2010 and passed all the structural tests," Hodgetts reveals. "MIRA went on to test the tables against the injury criteria set out by the Rail Safety and Standards Board, and the tables passed all the test categories. They were the first tables to be tested using the new HSIII hybrid instrumented dummy."

BB retained the intellectual property rights for the tables and has since also manufactured the product for Arriva Trains Wales, Northern Rail and other customers.

### Universal Access Toilet module

In 2011, BB teamed up with a leading train operating company (TOC) that had installed PRM TSI-compliant toilet modules in its vehicles. BB wanted to develop its own toilet module that could be manufactured in the UK in time for installation before 2020, when the PRM TSI regulations come into force.

"We did not want to develop a toilet module without the expert input of the companies that would be responsible for installing them," continues Hodgetts. "Although the original toilet modules had been installed in Chiltern Railways vehicles, we wanted to optimise the design in terms of the materials, manufacture, installation and service maintenance."

The first module was built at the end of 2012, and in February 2013 BB invited UK rolling stock operating companies, TOCs, rolling stock manufacturers and engineering companies to review it. BB's in-house design engineering team incorporated the feedback from these focus meetings into a second-generation Universal Access Toilet (UAT) module, which will be on display on stand



TOP: Class 158s operated by Arriva Trains Wales feature folding tables from Bakerbellfield  
 ABOVE: Tables can be supplied with integrated power sockets  
 BELOW: Railcar interior for Southern Trains

dispensers, as well as the hand-dryer – a feature that BB says was incorporated in light of criticism due to the operating sequence on some existing designs.

The company also paid a lot of attention to optimising the unit in terms of maintenance. For example, parts will be coded to enable easy identification and the maintenance manual will be accessible using an Android phone or other device. If authorised personnel need to perform maintenance on the vanity unit, they can do so from inside the module.

The controls for the UAT are all located behind one external door. BB says avoiding a second external access door reduces the module's overall dimensions, allowing more space for seating in the carriage. During refurbishment, the vanity unit can be taken out completely, or parts can be replaced individually.

The module's exterior is constructed from lightweight aluminium panels, while resin panels were used for the interior. "As well as the PRM TSI regulation, the module is compliant with the GM/RT 2100 and EN12663-1 structural standards, and the wiring is designed to meet the Rail Electrical Compliance EN 50155, EN61373, EN 50121-3-2 and RIA 12 standards," Hodgetts notes.

The company is currently negotiating projects that would see it supply the toilet module to clients from November 2013. It is also working on two other concepts that Hodgetts promises will "provide advanced solutions for the rail industry". Details of these new concepts will be released shortly.

BB is also aiming to achieve BS EN 15085 accreditation for design and fabrication, in response to what Hodgetts reports as growing demand for engineered products. "The BS EN 15085 approval will increase our scope of supply to include safety-critical components in addition to interior components," he concludes. ☒

### CONTACT

darran@bakerbellfield.co.uk; www.bakerbellfield.co.uk



## The premier choice for advanced composite solutions

Premier Composite Technologies (PCT), is a leading global supplier and manufacturer of large scale, advanced, high quality, composite components for the Rail, Architecture, Construction and Marine markets.

The internationally renowned composite solutions company based in Dubai, is ideally positioned to serve a truly global customer base.



Cologne Germany  
12-14 November

Please visit our stand  
No: 3050

Dubai Investments Park, PO Box 282777, Dubai, UAE  
T +971 (0)4 886 8555 • F +971 (0)4 886 8500  
info@pct.ae • www.pct.ae



# FREE

## ONLINE SUBSCRIPTION AND READER ENQUIRY SERVICE!

Request more details about the advertisers in this issue of Railway Interiors International online at:

[www.ukipme.com/railway](http://www.ukipme.com/railway)





# Light relief

Low weight and high impact resistance were crucial aims in PCT's development of a front-end module for Queensland Rail's new Sunlander train

The Queensland Rail Sunlander 14 tilt train, designed and built by Downer Rail, will run between Brisbane and Cairns, Australia, from mid-2014. Premier Composite Technologies (PCT) of Dubai, UAE, was selected to produce eight front-end modules for the project, on the strength of its experience with pre-preg systems, high-accuracy machined tooling and extensive quality-control systems. The brief was to meet Downer's low target weight and exacting specification, while delivering high impact resistance to ensure driver safety on the unfenced Queensland rail network.

PCT worked with Downer to design and engineer a pre-preg laminate for the front-end parts, comprising carbon and glass fibres combined with a toughened epoxy resin system. PCT says the choice of pre-preg laminates, and in particular a large amount of carbon fibre pre-pregs, enabled it to deliver the all-important ballistic and impact performance while keeping panel weight to an absolute minimum. All laminate combinations were produced as test panels at PCT and sent to Australia for testing to the 49 CFR 223 Type II and BR 566:1989 Type II impact requirements.

PCT's scope was to supply a complete set of composite tooling, validate test panel performance, and produce eight new composite cab front-ends. All tooling and production parts were to be supplied with comprehensive CMM inspection reports using PCT's Leica laser tracking system.

With highly accurate tooling being a key project requirement, PCT was able to use its five-axis milling machine to produce one-piece master plugs before infusing epoxy mould tools from the plugs. The largest mould measures 3 x 3 x 3m.

The cab front parts themselves were laminated using a combination of a carbon fibre pre-preg with SAN foam core and glass fibre pre-preg with an aluminium honeycomb core. Every stage of the production process was managed through PCT's quality management system, with full material traceability provided by the business ERP system.

"CMM measurements were carried out for all the plugs, moulds and first article parts, with the client coming to PCT for first article sign-off," reveals Hannes Waimer, managing director at the company. "This commitment to high accuracy and quality is a massive benefit to clients such as Downer, which can be confident that all the parts shipped will meet precise assembly tolerances." The eight panels were shipped from Dubai in April 2013 for assembly in Australia.

For the same customer, PCT is also supplying 44 E-glass Vinyester-infused cab front ends, and 55 types of interior panel – including 4m-long window panels, door pillars and driver's cab panels (including the desk and partition panels) – for 22 trainsets.

PCT's composite portfolio also includes toilet modules with integrated vacuum toilets and tank systems. All its toilet modules are designed to meet standards such as TSI, UIC and RVAR.

PCT will be exhibiting at the Railway and Mass Transit Interiors Technology and Design Expo in Cologne, Germany, on 12-14 November 2013; displaying a prototype of a TSI/UIC-compliant toilet system and driver's cab module on stand 3050. ☒

CLOCKWISE FROM MAIN: PCT's five-axis CNC milling machine mills a cab front to precise specifications; a pre-preg laminate was used to create the cab; CMM inspection using a laser tracker

## CONTACT

info@pct.ae; www.pct.ae

## Flight of fancy

**E**ngineer Nigel Woolford spent two years rebuilding this luxury car, taking it from a rusty hulk to a carriage suitable for service on the Royal Scotsman. Passengers pay up to £4,000 a head for passage on this train, which takes in the beauty spots of Scotland and has been owned by the Orient Express group since 2005.

Woolford has been involved in the train's maintenance since 1987, latterly through his engineering business, Assenta. "This is the first new carriage built for the Royal Scotsman since 1996," he says. "We've done plenty of tweaks, tidy ups and maintenance over the years, but this has been totally hand built from the shell up." ❌



### EDWARDIANA

In keeping with the train being what Woolford terms "a country house on wheels", the design takes many of its cues from the Edwardian era. "I love the whole Edwardian thing when it comes to rail," says Woolford. "The carriages were decorative and decadent and the lifestyle of the people who owned and operated these trains was fantastic." That said, the car also benefits from modern amenities such as LED lighting.

### TIMBER

The Pullman carriage replaces an older car that had a timber frame - which was becoming increasingly difficult to maintain. The interior timber in the Pullman car was refurbished by Peter Craig. Mahogany is used in other parts of the train, but in this car Woolford chose West African sapele for sustainability reasons.

### MARQUETRY

In addition to the Scottish thistle, the elaborate marquetry incorporates the bird the carriage is named after - the swift. Woolford spent weeks on the design, which was manufactured by a Welsh company and then pressed and lacquered in Scotland by Peter Craig. The panels are made of exotic hardwoods, inlaid with matching pomele.



## INDEX TO ADVERTISERS

Aerolux.....	22
Amorim Cork Composites.....	46
Atlantic Design Projects Ltd.....	60
Baker Bellfield.....	<b>Outside Back Cover</b>
BOXMARK Leather GmbH + Co KG.....	<b>Inside Back Cover</b>
Cytec.....	45
E-Leather Ltd.....	9
Forbo Flooring System.....	21
Franz Kiel GmbH.....	60
Getzner Werkstoffe GmbH.....	37
Gummiwerk Kraiburg GmbH & Co. KG.....	73
HEXIS SA.....	56

Innova Composite.....	55
JULIEN.....	41
Korbadesign Slu.....	91
Kydex LLC.....	51
LPA Excil Electronics PLC.....	18
Metsa Wood.....	49
MTAG Composites Limited.....	85
Premier Composite Technologies LLC.....	102
Productive Plastics Inc.....	38
RailPlan International.....	<b>Inside Front Cover</b>
Railway & Mass Transit Interiors Technology Design Expo 2013.....	10, 13, 14, 63

Railway Interiors International Online Reader Enquiry Service.....	2, 34, 42, 97, 102
Reed Exhibitions.....	79
RICA Seats - Riihimaa Metallikaluste Oy.....	56
Rogers Corporation.....	31
SBF Spezialleuchten GmbH.....	4
Scottish Development International.....	59
TDG Transit Design Group Inc.....	25
Tiflex Ltd.....	69
WASP Switches Limited.....	3



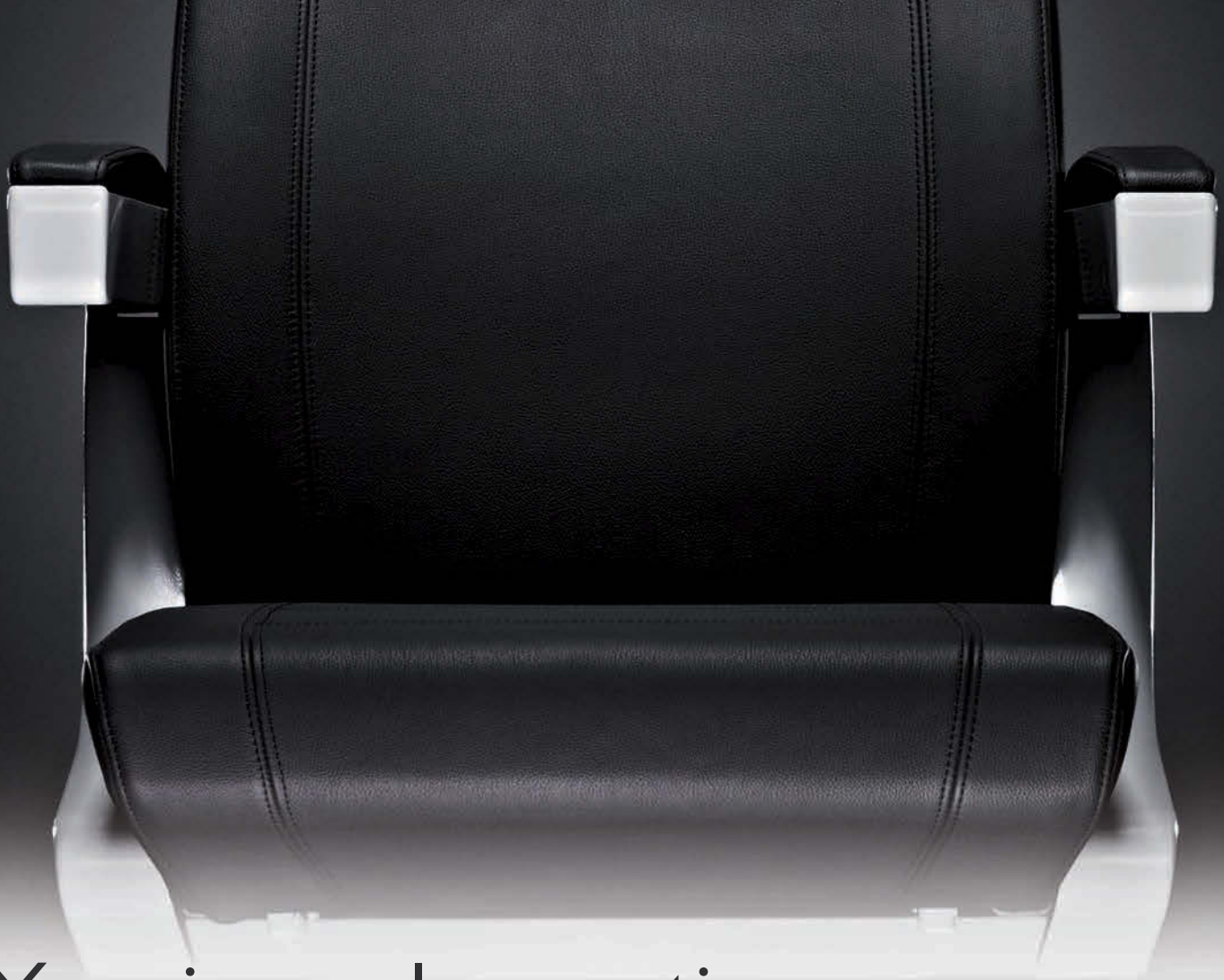

# Xperience Innovations.

**Xlight** - the innovation by BOXMARK - is a leather with a laminated weight of 600 gr/m<sup>2</sup>. This special product complies to all international standards and technical requirements for passenger transportation. It is the solution for effective weight reduction. Excellent technical values ensure easy cleaning and a long service life.

**Xtreme** represents a further advantage in the railway sector: The XTREME-treatment guarantees perfect protection against dirt and wear.

BOXMARK's modern manufacture offers all custom-made services for leather interior and exterior: Our product portfolio in the railway sector includes classic seating furniture, wall panels and built-in parts for trains and stations.

BOXMARK is one of the world's leading manufacturers of high-quality upholstery leather: The Austrian company supplies the premium segment of the automotive, furniture, aircraft, shipping and railway industry.

**The innovations and services of our manufacture will be presented at „Railway & Mass Transit Interiors Expo 2013“. Visit us at our Booth No. 2050.**

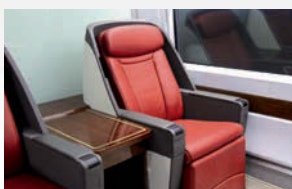

**BOXMARK**  
Best in Leather Interior

BOXMARK Leather GmbH & Co KG  
A-8380 Jennersdorf, Lederstraße 1, Phone: +43 3329 43300-0, Fax: +43 3329 43300-441, eduard.kettner@boxmark.com  
[www.boxmark.com](http://www.boxmark.com)



# RAIL INTERIOR SPECIALIST

